

**JOINT**  
**PUBLIC NOTICE**

**CHARLESTON DISTRICT, CORPS OF ENGINEERS**  
**1949 INDUSTRIAL PARK ROAD, ROOM 140**  
**CONWAY, SOUTH CAROLINA 29526**  
and  
**THE S.C. DEPARTMENT OF HEALTH AND ENVIRONMENTAL CONTROL**  
**Water Quality Certification and Wetlands Section**  
**2600 Bull Street**  
**Columbia, South Carolina 29201**

REGULATORY DIVISION  
Refer to: P/N SAC-2011-00314

20 December 2016

Pursuant to Section 10 of the Rivers and Harbors Act of 1899 (33 U.S.C. 403), Sections 401 and 404 of the Clean Water Act (33 U.S.C. 1344), the South Carolina Coastal Zone Management Act (48-39-10 et seq.), and the S.C. Construction in Navigable Waters Permit Program (R. 19-450, et seq., 1976 S.C. Code of Laws, as amended), an application has been submitted to the Department of the Army and the S.C. Department of Health and Environmental Control by

**Salem Woods Holdings, LLC**  
**C/O Mr. G. Alan Wood**  
**The EARTHWORKS Group**  
**P.O. Box 201**  
**Murrells Inlet, South Carolina 29576**

for a permit to construct twelve (12) joint use docks, one (1) community dock, two (2) individual use docks and the associated dredging of each within the

**ATLANTIC INTRACOASTAL WATERWAY (AIWW)**

at a location north of and adjacent to U.S. Highway 17 Bypass, located near Myrtle Beach International Airport, in Myrtle Beach, Horry County, South Carolina (Latitude: 33.6939°N, Longitude: -78.9487°W), Myrtle Beach Quad.

In order to give all interested parties an opportunity to express their views

**NOTICE**

is hereby given that written statements regarding the proposed work will be received by the **Corps** until

**15 Days from the Date of this Notice,**

and **SCDHEC** will receive written statements regarding the proposed work until

**30 Days from the Date of this Notice**

from those interested in the activity and whose interests may be affected by the proposed work.

The proposed work involves the construction of twelve (12) joint use docks, one (1)

community dock, two (2) individual use docks and associated dredging of each structure. In detail the proposed work consists of the following as stated by the applicant:

**Dock 1 - Community Dock:** 4' x 77' walkway extending from the existing seawall to a 12' x 16' fixed pierhead with roof (1' eaves for 14' x 18'; 252 S.F. shaded), 3' x 15' ramp and 8' x 20' (160 S.F.) floating dock. Dredging will involve removing 24 C.Y. of bottom material from a 0.017 Ac. (741 S.F.) area in the AIWW.

**Dock 2 – Joint-Use Dock:** 4' x 111' walkway extending from the existing seawall to a 12' x 12' fixed pierhead with roof (1' eaves for 14' x 14'; 196 S.F. shaded) and two (2) 12' x 12' four pile boatlifts, one on each side of the pierhead with a 3' x 3' access platform. Dredging will involve removing 49 C.Y. of bottom material from a 0.030 Ac. (1,307 S.F.) area in the AIWW.

**Dock 3 – Joint-Use Dock:** 4' x 101' walkway extending from the existing seawall to a 12' x 12' fixed pierhead with roof (1' eaves for 14' x 14'; 196 S.F. shaded) and two (2) 12' x 12' four pile boatlifts, one on each side of the pierhead with a 3' x 3' access platform. Dredging will involve removing 12 C.Y. of bottom material from a 0.021 Ac. (915 S.F.) area in the AIWW.

**Dock 4 – Joint-Use Dock:** 4' x 102' walkway extending from the existing seawall to a 12' x 12' fixed pierhead with roof (1' eaves for 14' x 14'; 196 S.F. shaded) and two (2) 12' x 12' four pile boatlifts, one on each side of the pierhead with a 3' x 3' access platform. Dredging will involve removing 2 C.Y. of bottom material from a 0.016 Ac. (697 S.F.) area in the AIWW.

**Dock 5 – Joint-Use Dock:** 4' x 73' walkway extending from the existing seawall to a 12' x 12' fixed pierhead with roof (1' eaves for 14' x 14'; 196 S.F. shaded) and two (2) 12' x 12' four pile boatlifts, one on each side of the pierhead with a 3' x 3' access platform. Dredging will involve removing 9 C.Y. of bottom material from a 0.023 Ac. (1,002 S.F.) area in the AIWW.

**Dock 6 – Joint-Use Dock:** 4' x 50' walkway extending from the existing seawall to a 12' x 12' fixed pierhead with roof (1' eaves for 14' x 14'; 196 S.F. shaded) and two (2) 12' x 12' four pile boatlifts, one on each side of the pierhead with a 3' x 3' access platform. Dredging will involve removing 9 C.Y. of bottom material from a 0.018 Ac. (784 S.F.) area in the AIWW.

**Dock 7 – Joint-Use Dock:** 4' x 52' walkway extending from the existing seawall to a 12' x 12' fixed pierhead with roof (1' eaves for 14' x 14'; 196 S.F. shaded) and two (2) 12' x 12' four pile boatlifts, one on each side of the pierhead with a 3' x 3' access platform. Dredging will involve removing 43 C.Y. of bottom material from a 0.032 Ac. (1,394 S.F.) area in the AIWW.

**Dock 8 – Joint-Use Dock:** 4' x 52' walkway extending from the existing seawall to a 12' x 12' fixed pierhead with roof (1' eaves for 14' x 14'; 196 S.F. shaded) and two (2) 12' x 12' four pile boatlifts, one on each side of the pierhead with a 3' x 3' access platform. Dredging will involve removing 101 C.Y. of bottom material from a 0.045 Ac. (1,960 S.F.) area in the AIWW.

**Dock 9 – Joint-Use Dock:** 4' x 52' walkway extending from the existing seawall to a 12' x 12' fixed pierhead with roof (1' eaves for 14' x 14'; 196 S.F. shaded) and two (2) 12' x 12' four pile boatlifts, one on each side of the pierhead with a 3' x 3' access platform. Dredging will involve removing 143 C.Y. of bottom material from a 0.058 Ac. (2,526 S.F.) area in the AIWW.

**Dock 10 – Joint-Use Dock:** 4' x 54' walkway extending from the existing seawall to a 12' x 12' fixed pierhead with roof (1' eaves for 14' x 14'; 196 S.F. shaded) and two (2) 12' x 12' four pile boatlifts, one on each side of the pierhead with a 3' x 3' access platform. Dredging will involve

removing 105 C.Y. of bottom material from a 0.057 Ac. (2,483 S.F.) area in the AIWW.

**Dock 11 – Joint-Use Dock:** 4' x 55' walkway extending from the existing seawall to a 12' x 12' fixed pierhead with roof (1' eaves for 14' x 14'; 196 S.F. shaded) and two (2) 12' x 12' four pile boatlifts, one on each side of the pierhead with a 3' x 3' access platform. Dredging will involve removing 89 C.Y. of bottom material from a 0.049 Ac. (2,134 S.F.) area in the AIWW.

**Dock 12 – Joint-Use Dock:** 4' x 56' walkway extending from the existing seawall to a 12' x 12' fixed pierhead with roof (1' eaves for 14' x 14'; 196 S.F. shaded) and two (2) 12' x 12' four pile boatlifts, one on each side of the pierhead with a 3' x 3' access platform. Dredging will involve removing 60 C.Y. of bottom material from a 0.036 Ac. (1,568 S.F.) area in the AIWW.

**Dock 13 – Joint-Use Dock:** 4' x 52' walkway extending from the existing seawall to a 12' x 12' fixed pierhead with roof (1' eaves for 14' x 14'; 196 S.F. shaded) and two (2) 12' x 12' four pile boatlifts, one on each side of the pierhead with a 3' x 3' access platform. Dredging will involve removing 72 C.Y. of bottom material from a 0.038 Ac. (1,655 S.F.) area in the AIWW.

**Dock 14 – Individual Use Dock:** 4' x 45' walkway extending from the existing seawall to a 12' x 12' fixed pierhead with roof (1' eaves for 14' x 14'; 196 S.F. shaded), 3' x 14' ramp, 10' x 20' floating dock on the east side of the pierhead and a 12' x 12' four pile boatlift with a 3' x 3' access platform on the west side of the pierhead. Dredging will involve removing 177 C.Y. of bottom material from a 0.069 Ac. (3,006 S.F.) area in the AIWW.

**Dock 15 – Individual Use Dock:** 6' x 33' walkway extending from the existing seawall to a 12' x 14' fixed pierhead with roof (1' eaves for 14' x 16'; 224 S.F. shaded). Extending from the east side of the pierhead is a 4' x 16' ramp landing, 4' x 16' ramp, 230 S.F. floating dock and a 12' x 12' four pile boatlift. On the west side of the pierhead are two (2) 14' x 14' four pile boat lifts with a 34' x 50' cover.

**Dredging Method & Spoil Dewatering:** The project calls for excavation of channel bottom in the AIWW to create adequate water be available for vessel ingress/egress to dock and boat storage structures at normal low tide levels (elev. -0.08'). Existing bottom would be dredged to an elevation of -3.0' along the front of the boat lifts and slope slightly towards the AIWW centerline to meet the existing bottom elevation at -4.0'. The dredging area also includes profiling the landward and left/right sides of the excavated bottom at a 2:1 slope to the existing bottom elevation to prevent siltation/backfilling of the bottom.

Dredging would be conducted from the water by a barge mounted Cat 320 50' long-reach excavator removing bottom material to the desired depth. Dredged spoil material will initially be placed in a material hopper on the same barge the excavator is mounted on. The material hopper bin is sealed and offers no initial dewatering, however, the enclosure will be lined with straw bales to capture sediment and reduce potential for adverse water quality contamination in the event of breach. Once the barge basin is filled to capacity (approximately ten dump truck loads), the barge would be maneuvered to the nearby (<1 mile southwest by AIWW) Hauge Marina where spoil would be moved by excavator from the barge into a dump truck on land. The sealed bed dump truck would transport the spoil by road (2.5 mile) from the marina to the project site and offloaded into the designated spoil dewatering containment area located on Lot 50.

The applicant offered no compensatory mitigation for impacts associated with the project. The applicant stated that impacts to the aquatic resources have been avoided and minimized by

designing each dock and the associated dredging to only what is required in order to meet the purpose of the propose project. Alternate dock and dredging designs were considered for each of the dock types associated with the proposed project. It is understood that this work is to be conducted on/or adjacent to an area subject to a prism and/or disposal area held by the United States. Appropriate provisions will be included in the permit to ensure the interests of the Federal Government are understood. The project purpose as stated by the applicant is to provide private recreational boating access to the AIWW with dockage and boat storage for the owners of Lots 25-50 of the proposed subdivision.

**NOTE: This public notice and associated plans are available on the Corps' website at:**  
<http://www.sac.usace.army.mil/Missions/Regulatory/PublicNotices> .

The District Engineer has concluded that the discharges associated with this project, both direct and indirect, should be reviewed by the South Carolina Department of Health and Environmental Control in accordance with provisions of Section 401 of the Clean Water Act. As such, this notice constitutes a request, on behalf of the applicant, for certification that this project will comply with applicable effluent limitations and water quality standards. The work shown on this application must also be certified as consistent with applicable provisions of the Coastal Zone Management Program (15 CFR 930). This activity may also require evaluation for compliance with the S. C. Construction in Navigable Waters Permit Program. State review, permitting and certification is conducted by the S. C. Department of Health and Environmental Control. The District Engineer will not process this application to a conclusion until such certifications are received. The applicant is hereby advised that supplemental information may be required by the State to facilitate the review.

This notice initiates the Essential Fish Habitat (EFH) consultation requirements of the Magnuson-Stevens Fishery Conservation and Management Act. Implementation of the proposed project would impact 0.625 acres of estuarine substrates and emergent wetlands utilized by various life stages of species comprising the shrimp, and snapper-grouper management complexes. The District Engineer's initial determination is that the proposed action would not have a substantial individual or cumulative adverse impact on EFH or fisheries managed by the South Atlantic Fishery Management Council and the National Marine Fisheries Service (NMFS). The District Engineer's final determination relative to project impacts and the need for mitigation measures is subject to review by and coordination with the NMFS.

Pursuant to the Section 7 of the Endangered Species Act of 1973 (as amended), the Corps has reviewed the project area, examined all information provided by the applicant, and the District Engineer has determined, based on the most recently available information that the West Indian Manatee (*Trichechus manatus*), Shortnose Sturgeon (*Acipenser brevirostrum*), and Atlantic sturgeon (*Acipenser oxyrinchus oxyrinchus*), Federally *endangered* species are present in the vicinity of the project. However, it has been determined that the project will have no effect on Shortnose Sturgeon (*Acipenser brevirostrum*), or Atlantic sturgeon (*Acipenser oxyrinchus oxyrinchus*), and will not result in the destruction or adverse modification of designated or proposed critical habitat. Additionally, the District Engineer has determined that the project is not likely to adversely affect the West Indian Manatee (*Trichechus manatus*) or result in the destruction or adverse modification of designated or proposed critical habitat. This public notice serves as a request for written concurrence from the U.S. Fish and Wildlife Service and/or the National Marine Fisheries Service on this determination.



Pursuant to Section 106 of the National Historic Preservation Act (NHPA), this public notice also constitutes a request to Indian Tribes to notify the District Engineer of any historic properties of religious and cultural significance to them that may be affected by the proposed undertaking.

In accordance with Section 106 of the NHPA, the District Engineer has consulted South Carolina ArchSite (GIS), for the presence or absence of historic properties (as defined in 36 C.F.R. 800.16)(f)(1)), and has initially determined that no historic properties are present; therefore, there will be no effect on historic properties. To ensure that other historic properties that the District Engineer is not aware of are not overlooked, this public notice also serves as a request to the State Historic Preservation Office and any other interested parties to provide any information they may have with regard to historic properties. This public notice serves as a request for concurrence within 30 days from the SHPO (and/or Tribal Historic Preservation Officer).

The District Engineer's final eligibility and effect determination will be based upon coordination with the SHPO and/or THPO, as appropriate and required and with full consideration given to the proposed undertaking's potential direct and indirect effects on historic properties within the Corps-identified permit area.

Any person may request, in writing, within the comment period specified in this notice, that a public hearing be held to consider this application. Requests for a public hearing shall state, with particularity, the reasons for holding a public hearing.

The decision whether to issue a permit will be based on an evaluation of the probable impact including cumulative impacts of the activity on the public interest. The benefit which reasonably may be expected to accrue from the project must be balanced against its reasonably foreseeable detriments. All factors which may be relevant to the project will be considered including the cumulative effects thereof; among those are conservation, economics, aesthetics, general environmental concerns, wetlands, historic properties, fish and wildlife values, flood hazards, flood plain values, land use, navigation, shoreline erosion and accretion, recreation, water supply and conservation, water quality, energy needs, safety, food and fiber production and, in general, the needs and welfare of the people. A permit will be granted unless the District Engineer determines that it would be contrary to the public interest. In cases of conflicting property rights, the Corps cannot undertake to adjudicate rival claims.

The Corps is soliciting comments from the public; Federal, state, and local agencies and officials; Indian Tribes; and other interested parties in order to consider and evaluate the impacts of this activity. Any comments received will be considered by the Corps to determine whether to issue, modify, condition or deny a permit for this project. To make this decision, comments are used to assess impacts on endangered species, historic properties, water quality, general environmental effects, and the other public interest factors listed above. Comments are used in the preparation of an Environmental Assessment and/or an Environmental Impact Statement pursuant to the National Environmental Policy Act. Comments are also used to determine the need for a public hearing and to determine the overall public interest of the activity. **Please submit comments in writing, identifying the project of interest by public notice number, to the following address:**

**U.S. Army Corps of Engineers  
ATTN: REGULATORY DIVISION**

**1949 INDUSTRIAL PARK ROAD, ROOM 140  
CONWAY, SOUTH CAROLINA 29526**

If there are any questions concerning this public notice, please contact Rob Huff, Project Manager, at (843) 365-4239.

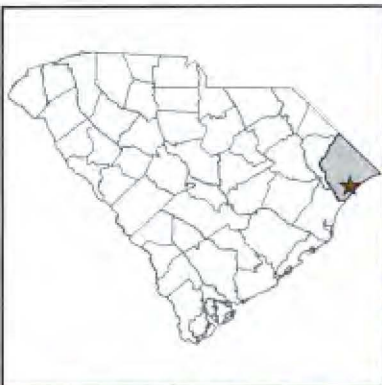

**Lauderdale Bay Docks**  
**SAC 2011-00314**  
**Horry County, South Carolina**  
**Dated: October 20, 2016**  
**Sheet 1 of 34**

**EARTHWORKS**  
*planning and design consultants*  
 11655 HIGHWAY 707  
 MURRELLS INLET, SC 29576  
 phone - 843-651-7900  
 fax - 843-651-7903  
 www.earthworksgroup.com

**SITE/VICINITY MAP**  
**LAUDERDALE BAY**  
 DOCK & DREDGE PERMITTING



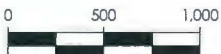

SCALE  
1:12,000  
1" = 1,000'

APPLICANT: SALEM WOODS HOLDINGS, LLC  
 ATTN: BEN THOMPSON  
 3306 GAITHER COURT  
 MYRTLE BEACH, SC 29588  
 LOCATION: US HWY 17 BYP. S. & LAUDERDALE BLVD.  
 MYRTLE BEACH, HORRY COUNTY, SC  
 LAT/LONG: 33.693733, -78.948624  
 USGS QUAD: MYRTLE BEACH  
 DATE: 10/20/2016

SHEET  
**S1.1**



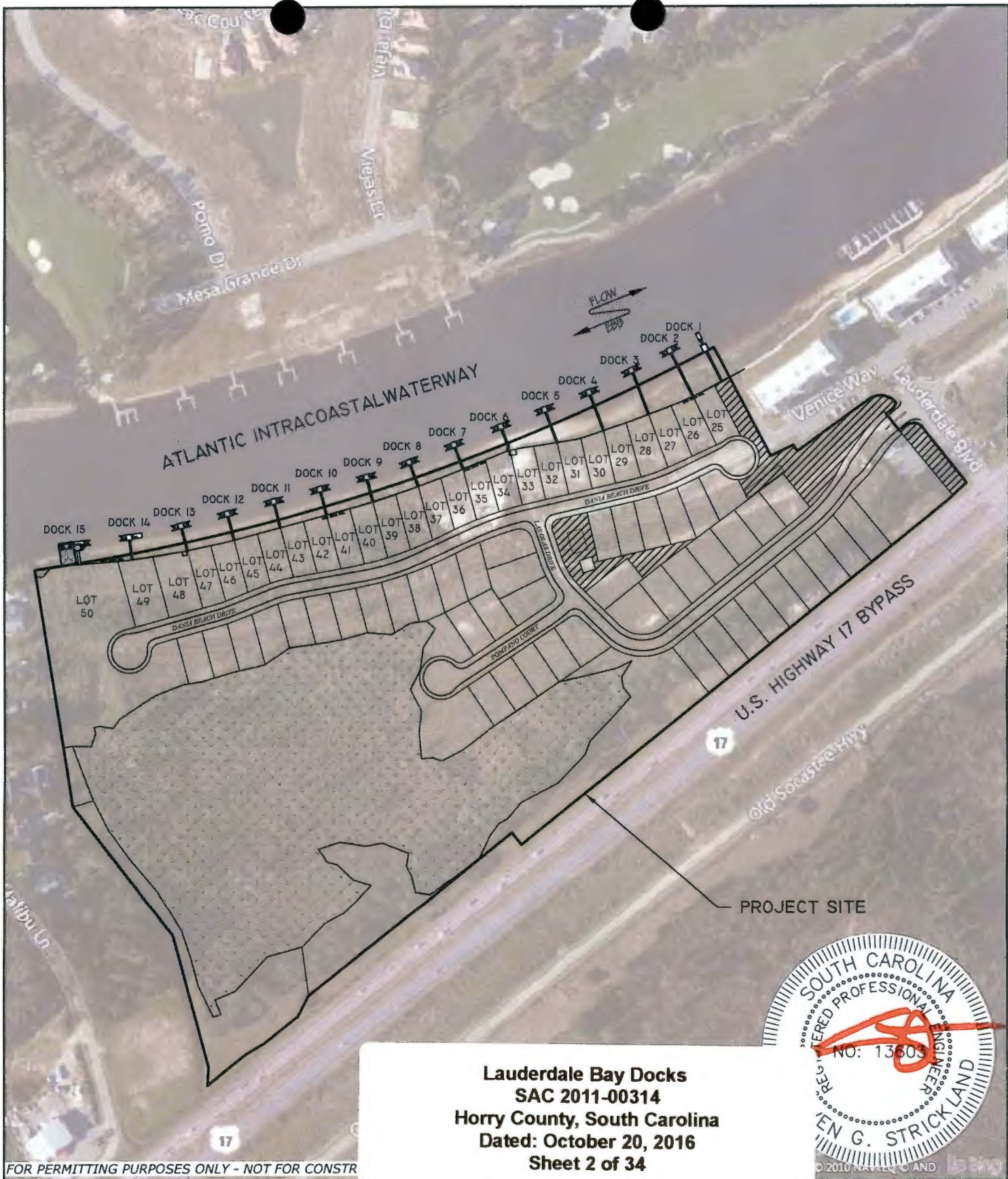

FOR PERMITTING PURPOSES ONLY - NOT FOR CONSTR

**Lauderdale Bay Docks**  
**SAC 2011-00314**  
**Horry County, South Carolina**  
**Dated: October 20, 2016**  
**Sheet 2 of 34**



**EARTHWORKS**  
*planning and design consultants*  
 11655 HIGHWAY 707  
 MURRELLS INLET, SC 29576  
 phone - 843.651.7900  
 fax - 843.651.7903  
 earthworksgroup.com

**SITE - OVERALL PROPOSED DEVELOPMENT & DOCKS**  
**LAUDERDALE BAY**  
 DOCK & DREDGE PERMITTING

SCALE  
 1" = 300'

APPLICANT: SALEM WOODS HOLDINGS, LLC  
 3306 GAITHER COURT  
 MYRTLE BEACH, SC 29588

LOCATION: US. HWY 17 BYPASS & LAUDERDALE BLVD.  
 HORRY COUNTY, SOUTH CAROLINA

LAT/LONG: 33.693733, -78.948624  
 USGS QUAD: MYRTLE BEACH

DATE: 12/12/16

TEG PN: 151096

**SHEET \$1.3**



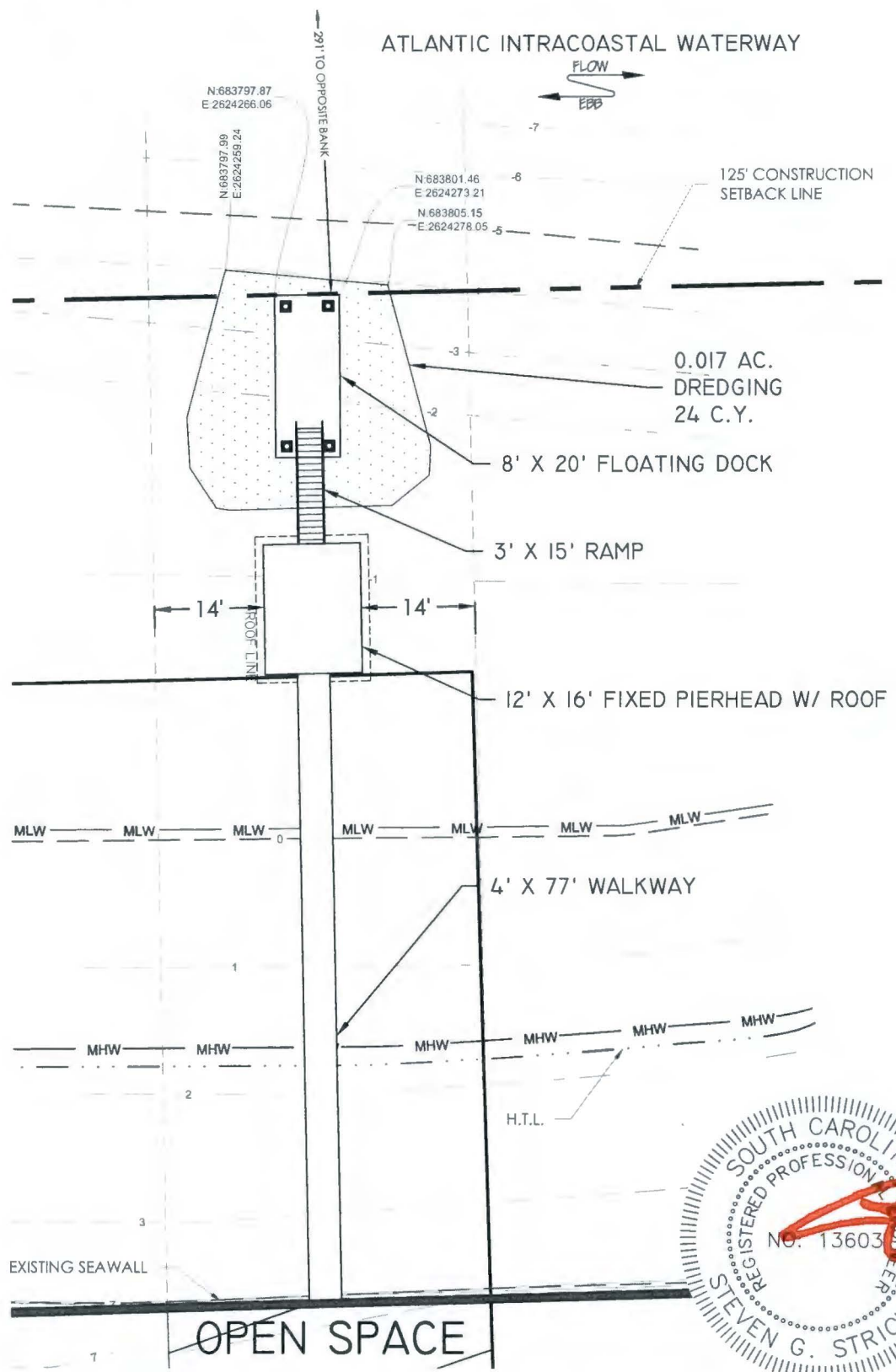

FOR PERMITTING PURPOSES ONLY - NOT FOR CONSTRUCTION

**EARTHWORKS**  
*planning and design consultants*  
 11655 HIGHWAY 707  
 MURRELLS INLET, SC 29576  
 phone - 843.651.7900  
 fax - 843.651.7903  
 earthworksgroup.com

**DOCK 1 COMMUNITY OPEN SPACE - PROPOSED**  
 LAUDERDALE BAY  
 DOCK & DREDGE PERMITTING

APPLICANT: SALEM WOODS HOLDINGS, LLC  
 3306 GAITHER COURT  
 MYRTLE BEACH, SC 29588

**Lauderdale Bay Docks**  
**SAC 2011-00314**  
 Horry County, South Carolina  
 Dated: October 20, 2016  
 Sheet 3 of 34

# DOCK 1

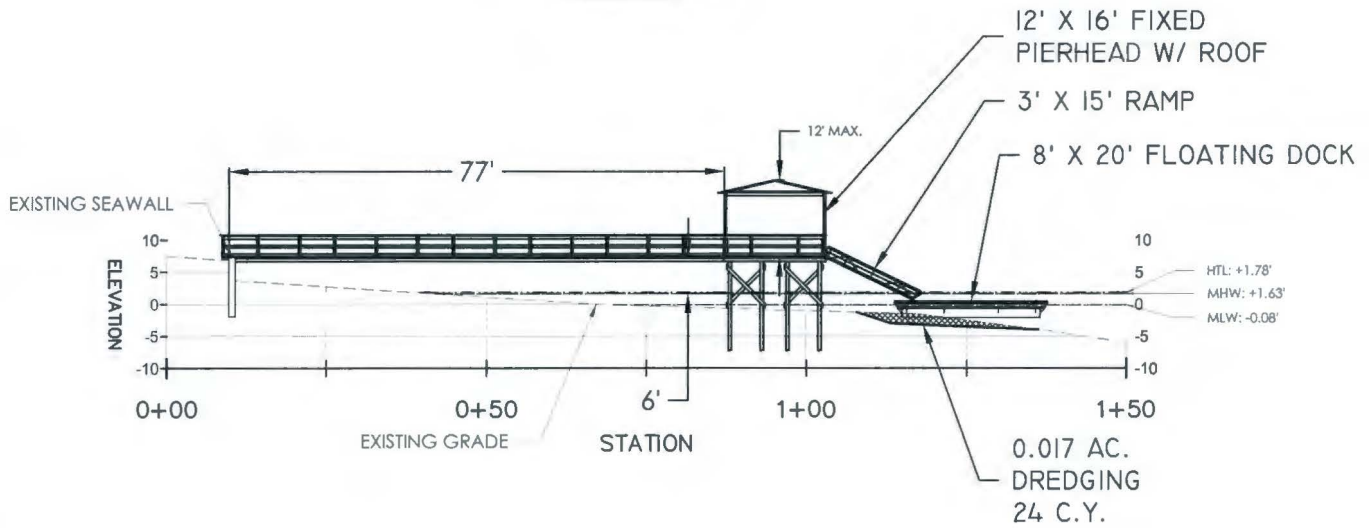

**Lauderdale Bay Docks  
SAC 2011-00314  
Horry County, South Carolina  
Dated: October 20, 2016  
Sheet 4 of 34**

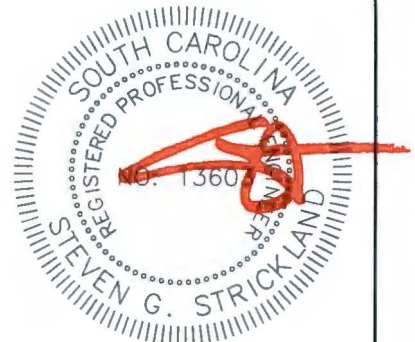

ELEVATION DATUM: NAVD88

FOR PERMITTING PURPOSES ONLY - NOT FOR CONSTRUCTION

**EARTHWORKS**  
planning and design consultants

11655 HIGHWAY 707  
MURRELLS INLET, SC 29576  
phone - 843.651.7900  
fax - 843.651.7903  
earthworksgroup.com

**DOCK 1  
PROFILE VIEW  
LAUDERDALE BAY  
DOCK & DREDGE PERMITTING**

0      15      30

SCALE  
1" = 30'

APPLICANT: SALEM WOODS HOLDINGS, LLC  
3306 GAITHER COURT  
MYRTLE BEACH, SC 29588

LOCATION: US. HWY 17 BYPASS & LAUDERDALE BLVD.  
HORRY COUNTY, SOUTH CAROLINA

LAT/LONG: 33° 42' 37.00" N 79° 08' 24.00" W

SHEET  
**D1.3**

ATLANTIC INTRACOASTAL WATERWAY



0.030 AC.  
DREDGING  
49 C.Y.  
12' X 12' FIXED  
PIERHEAD W/ ROOF

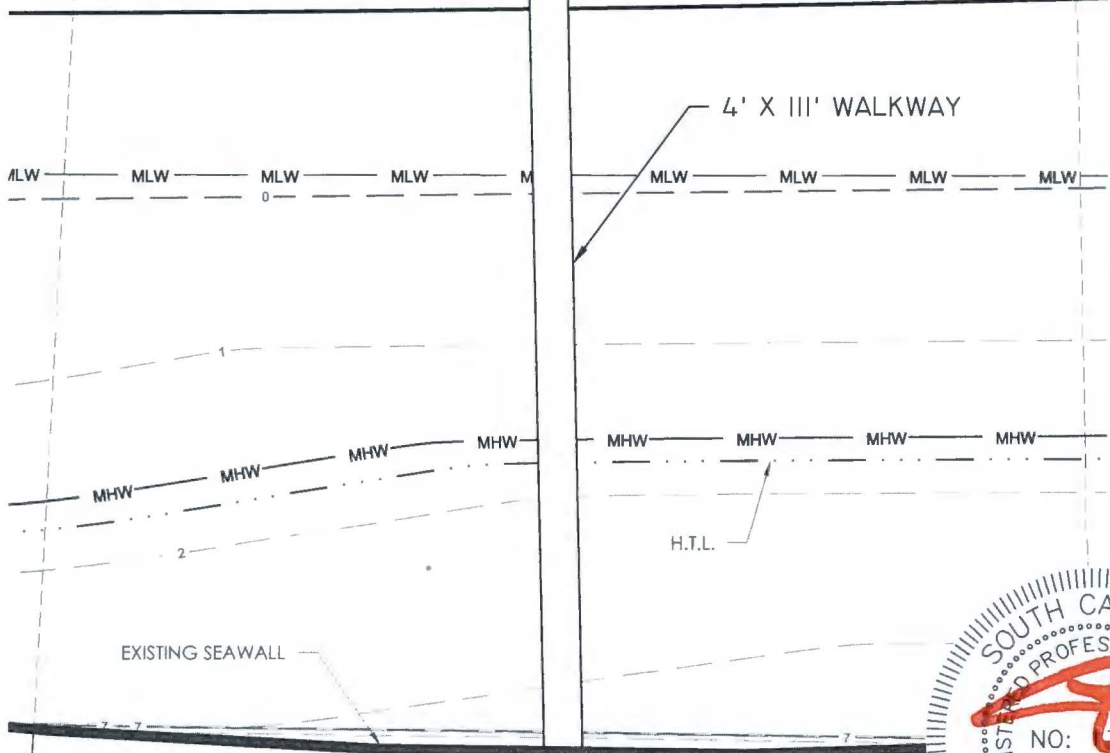
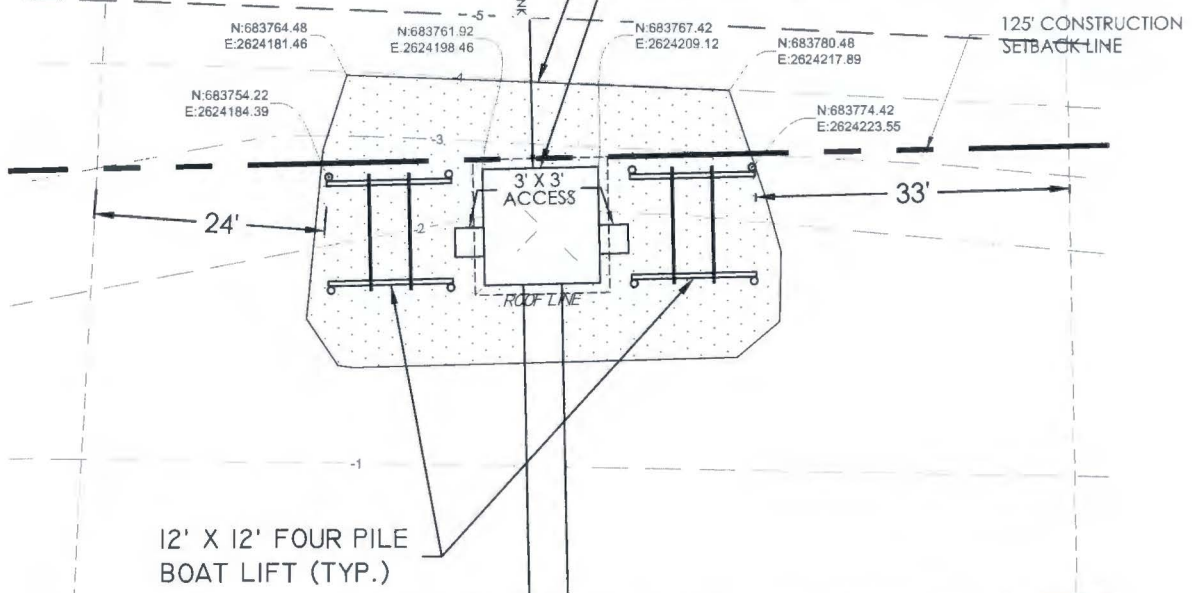

EXISTING SEAWALL

EXST. BLOCK WALL

LOT 26

LOT 25



FOR PERMITTING PURPOSES ONLY - NOT FOR CONSTRUCTION

**Lauderdale Bay Docks**  
**SAC 2011-00314**  
**Horry County, South Carolina**  
**Dated: October 20, 2016**  
**Sheet 5 of 34**

earthworksgroup.com

**CK 2 - LOT 25 & 26**  
**PROPOSED**  
**LAUDERDALE BAY**  
DOCK & DREDGE PERMITTING



SCALE  
1" = 20'

APPLICANT: SALEM WOODS HOLDINGS, LLC  
3306 GAITHER COURT  
MYRTLE BEACH, SC 29588

LOCATION: US. HWY 17 BYPASS & LAUDERDALE BLVD.  
HORRY COUNTY, SOUTH CAROLINA  
LAT/LONG: 33.693733, -78.948624  
USGS QUAD: MYRTLE BEACH

DATE: 12/12/16

TEG PN: 151096

SHEET  
**D2.2**



# DOCK 2

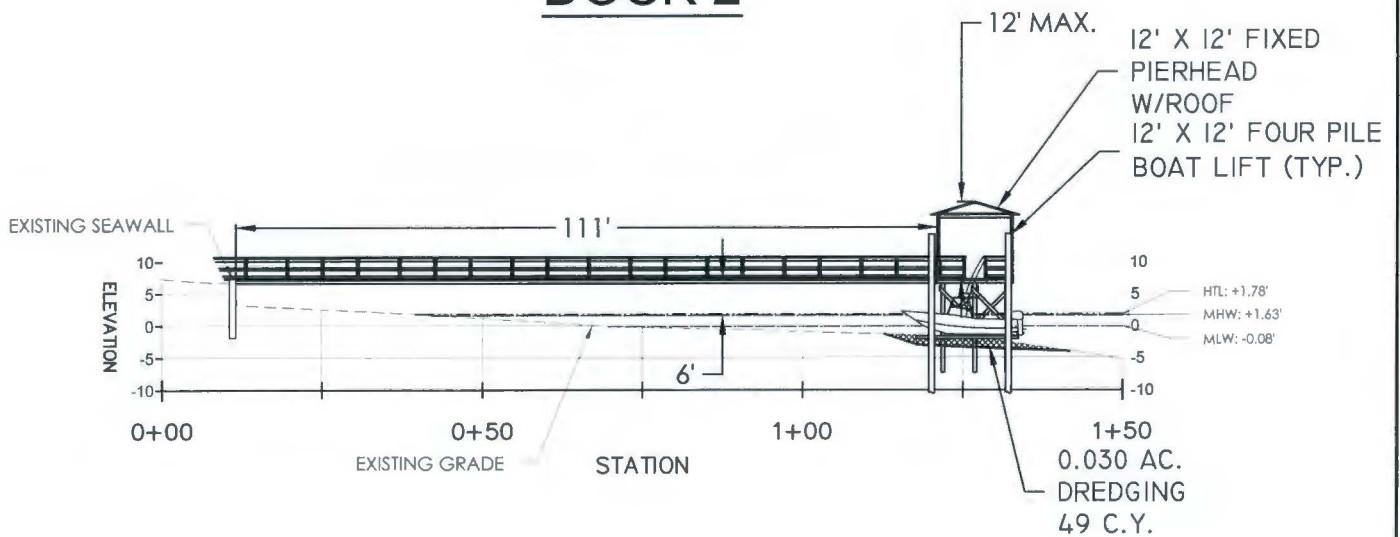

**Lauderdale Bay Docks**  
**SAC 2011-00314**  
**Horry County, South Carolina**  
**Dated: October 20, 2016**  
**Sheet 6 of 34**

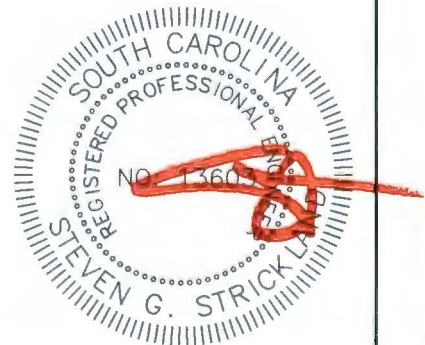



ELEVATION DATUM: NAVD88

FOR PERMITTING PURPOSES ONLY - NOT FOR CONSTRUCTION

**EARTHWORKS**  
*planning and design consultants*  
 11655 HIGHWAY 707  
 MURRELLS INLET, SC 29576  
 phone - 843.651.7900  
 fax - 843.651.7903  
 earthworksgroup.com

**DOCK 2 LOT 25 & 26**  
**PROFILE VIEW**  
**LAUDERDALE BAY**  
 DOCK & DREDGE PERMITTING



 SCALE  
 1" = 30'

APPLICANT: SALEM WOODS HOLDINGS, LLC  
 3306 GAITHER COURT  
 MYRTLE BEACH, SC 29588

LOCATION: US. HWY 17 BYPASS & LAUDERDALE BLVD.  
 HORRY COUNTY, SOUTH CAROLINA  
 LAT/LONG: 33.693733, -78.948624  
 USGS QUAD: MYRTLE BEACH

DATE: 12/12/16

SHEET  
**D2.3**

TEG PN: 151096

ATLANTIC INTRACOASTAL WATERWAY



12' X 12' FIXED PIERHEAD W/ ROOF

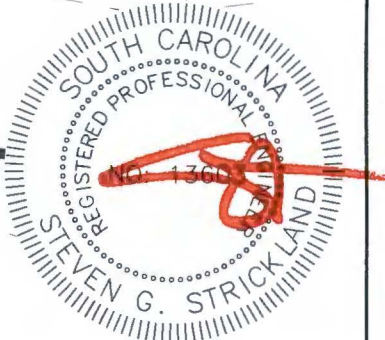
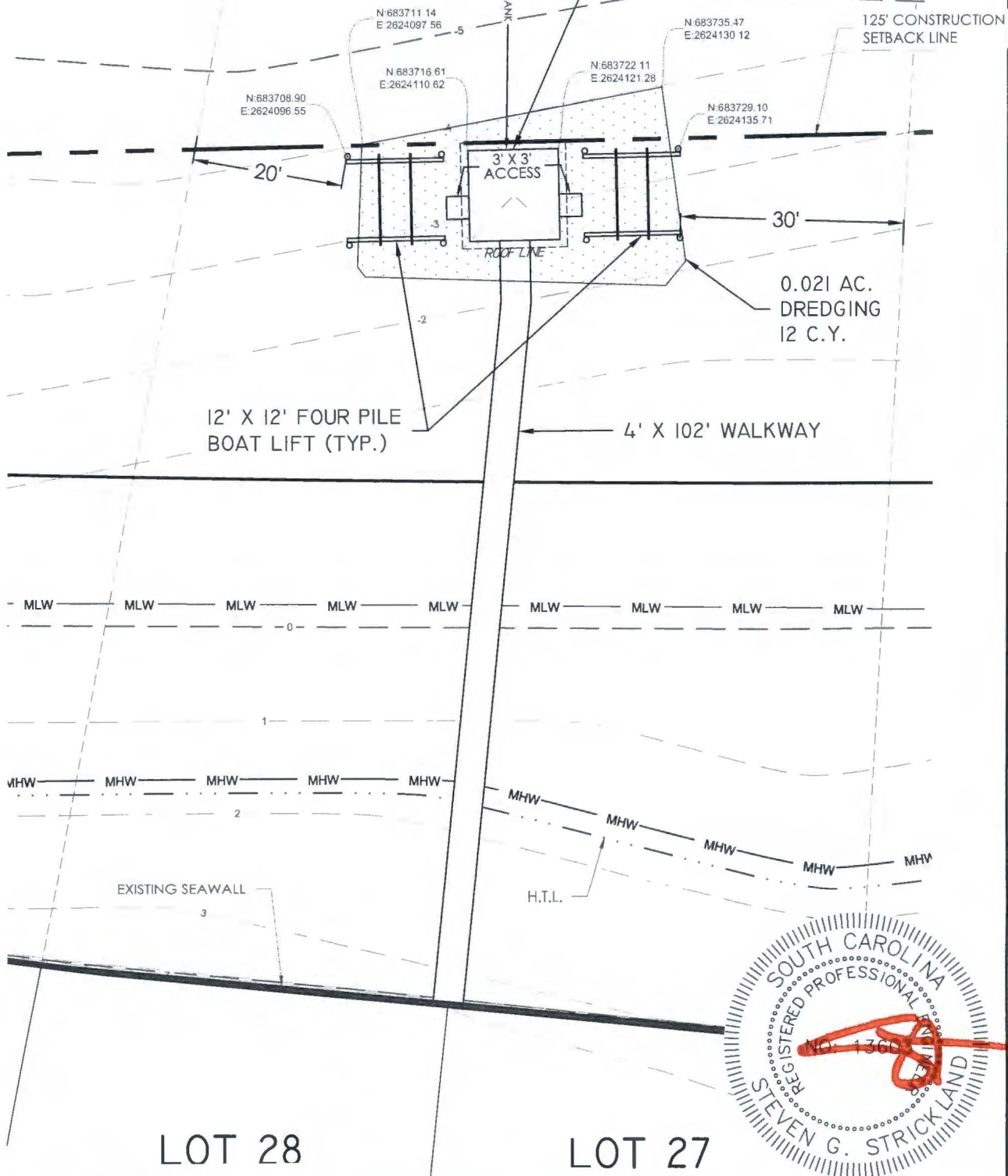

LOT 28

LOT 27

Lauderdale Bay Docks  
SAC 2011-00314  
Horry County, South Carolina  
Dated: October 20, 2016  
Sheet 7 of 34

phone - 843.651.7900  
fax - 843.651.7903  
earthworksgroup.com



**K 3 - LOT 27 & 28**  
**PROPOSED**  
LAUDERDALE BAY  
DOCK & DREDGE PERMITTING



SCALE  
1" = 20'

APPLICANT: SALEM WOODS HOLDINGS, LLC  
3306 GAITHER COURT  
MYRTLE BEACH, SC 29588

LOCATION: US. HWY 17 BYPASS & LAUDERDALE BLVD.  
HORRY COUNTY, SOUTH CAROLINA  
LAT/LONG: 33.693733, -78.948624  
USGS QUAD: MYRTLE BEACH

DATE: 12/12/16  
TEG PN: 151096

SHEET  
**D3.2**

# DOCK 3

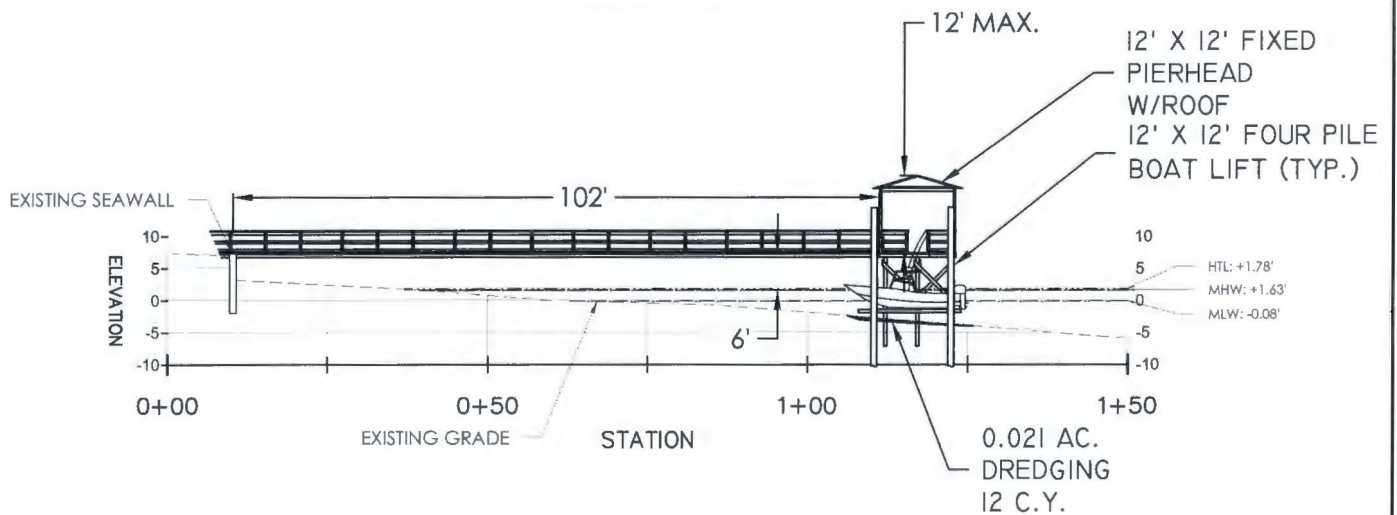

Lauderdale Bay Docks  
 SAC 2011-00314  
 Horry County, South Carolina  
 Dated: October 20, 2016  
 Sheet 8 of 34

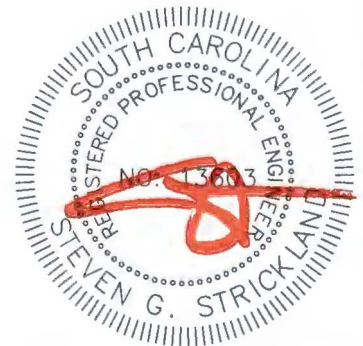

ELEVATION DATUM: NAVD88

FOR PERMITTING PURPOSES ONLY - NOT FOR CONSTRUCTION

**EARTHWORKS**  
 planning and design consultants  
 11655 HIGHWAY 707  
 MURRELLS INLET, SC 29576  
 phone - 843.651.7900  
 fax - 843.651.7903  
 earthworksgroup.com

**DOCK 3 - LOT 27 & 28**  
**PROFILE VIEW**  
 LAUDERDALE BAY  
 DOCK & DREDGE PERMITTING

0 15 30 SCALE 1" = 30'

APPLICANT: SALEM WOODS HOLDINGS, LLC  
 3306 GAITHER COURT  
 MYRTLE BEACH, SC 29588

LOCATION: US, HWY 17 BYPASS & LAUDERDALE BLVD.  
 HORRY COUNTY, SOUTH CAROLINA  
 LAT/LONG: 33.693733, -78.948624  
 USGS QUAD: MYRTLE BEACH

DATE: 12/12/16

SHEET D3.3

TEG PN: 151096



ATLANTIC INTRACOASTAL WATERWAY



12' X 12' FIXED PIERHEAD W/ ROOF

125' CONSTRUCTION SETBACK LINE

N:683664.37  
E:2624000.25

N:683678.84  
E:2624037.68  
N:683677.37  
E:2624040.28

N:683661.59  
E:2623999.13

N:683667.70  
E:2624013.96

N:683672.00  
E:2624025.17

317' TO OPPOSITE BANK

3' X 3' ACCESS

0.016 AC. DREDGING  
2 C.Y.

19'

41'

12' X 12' FOUR PILE BOAT LIFT (TYP.)

4' X 87' WALKWAY



H.T.L.

EXISTING SEAWALL

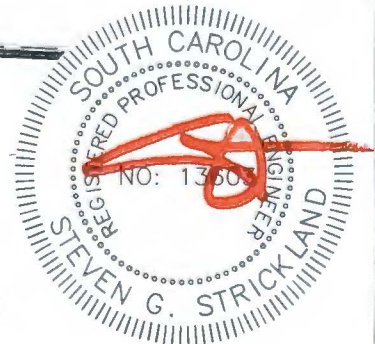

LOT 30

LOT 29

Lauderdale Bay Docks  
SAC 2011-00314  
Horry County, South Carolina  
Dated: October 20, 2016  
Sheet 9 of 34

4 - LOT 29 & 30  
PROPOSED  
LAUDERDALE BAY  
DOCK & DREDGE PERMITTING

APPLICANT: SALEM WOODS HOLDINGS, LLC  
3306 GAITHER COURT  
MYRTLE BEACH, SC 29588

LOCATION: US. HWY 17 BYPASS & LAUDERDALE BLVD.  
HORRY COUNTY, SOUTH CAROLINA  
LAT/LONG: 33.693733, -78.948624  
USGS QUAD: MYRTLE BEACH

PHONE - 843.651.7700  
FAX - 843.651.7903  
earthworksgroup.com



SCALE  
1" = 20'

DATE: 12/12/16

SHEET  
D4.2

TEG PN: 151096

# DOCK 4

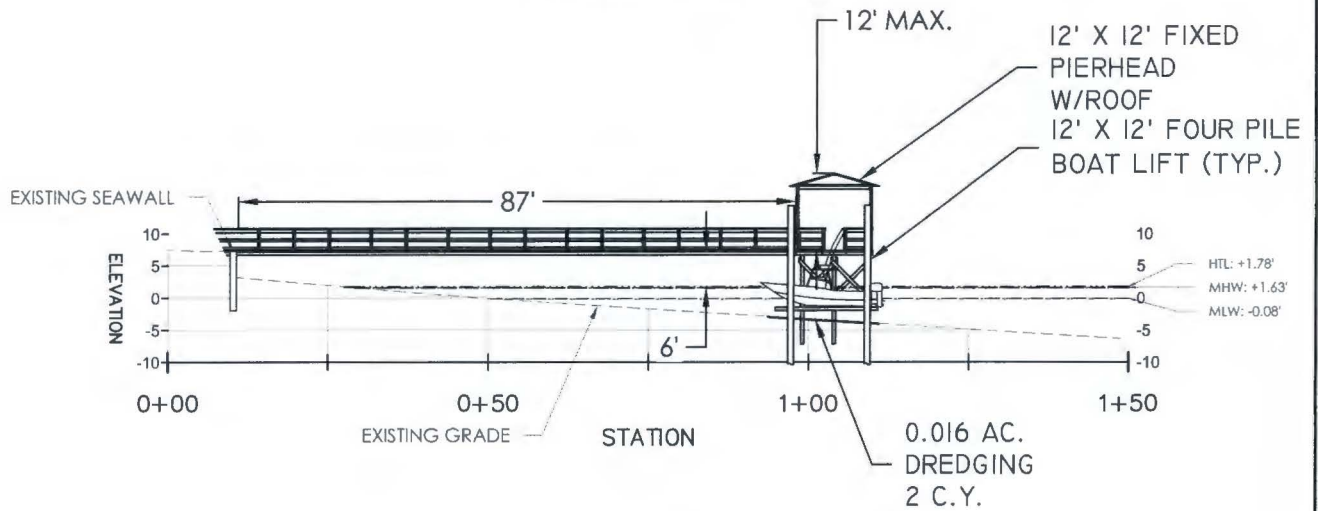

**Lauderdale Bay Docks**  
**SAC 2011-00314**  
**Horry County, South Carolina**  
**Dated: October 20, 2016**  
**Sheet 10 of 34**

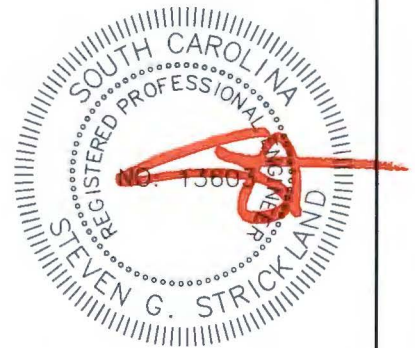

ELEVATION DATUM: NAVD88

FOR PERMITTING PURPOSES ONLY - NOT FOR CONSTRUCTION

**EARTHWORKS**  
*planning and design consultants*

11655 HIGHWAY 707  
MURRELLS INLET, SC 29576  
phone - 843.651.7900  
fax - 843.651.7903  
earthworksgroup.com

**DOCK 4 - LOT 29 & 30**  
**PROFILE VIEW**  
**LAUDERDALE BAY**  
DOCK & DREDGE PERMITTING

0 15 30

SCALE  
1" = 30'

APPLICANT: SALEM WOODS HOLDINGS, LLC  
3306 GAITHER COURT  
MYRTLE BEACH, SC 29588

LOCATION: US. HWY 17 BYPASS & LAUDERDALE BLVD.  
HORRY COUNTY, SOUTH CAROLINA

LAT/LONG: 33.693733, -78.948624  
USGS QUAD: MYRTLE BEACH

DATE: 12/12/16

TEG PN: 151096

SHEET  
**D4.3**

ATLANTIC INTRACOASTAL WATERWAY

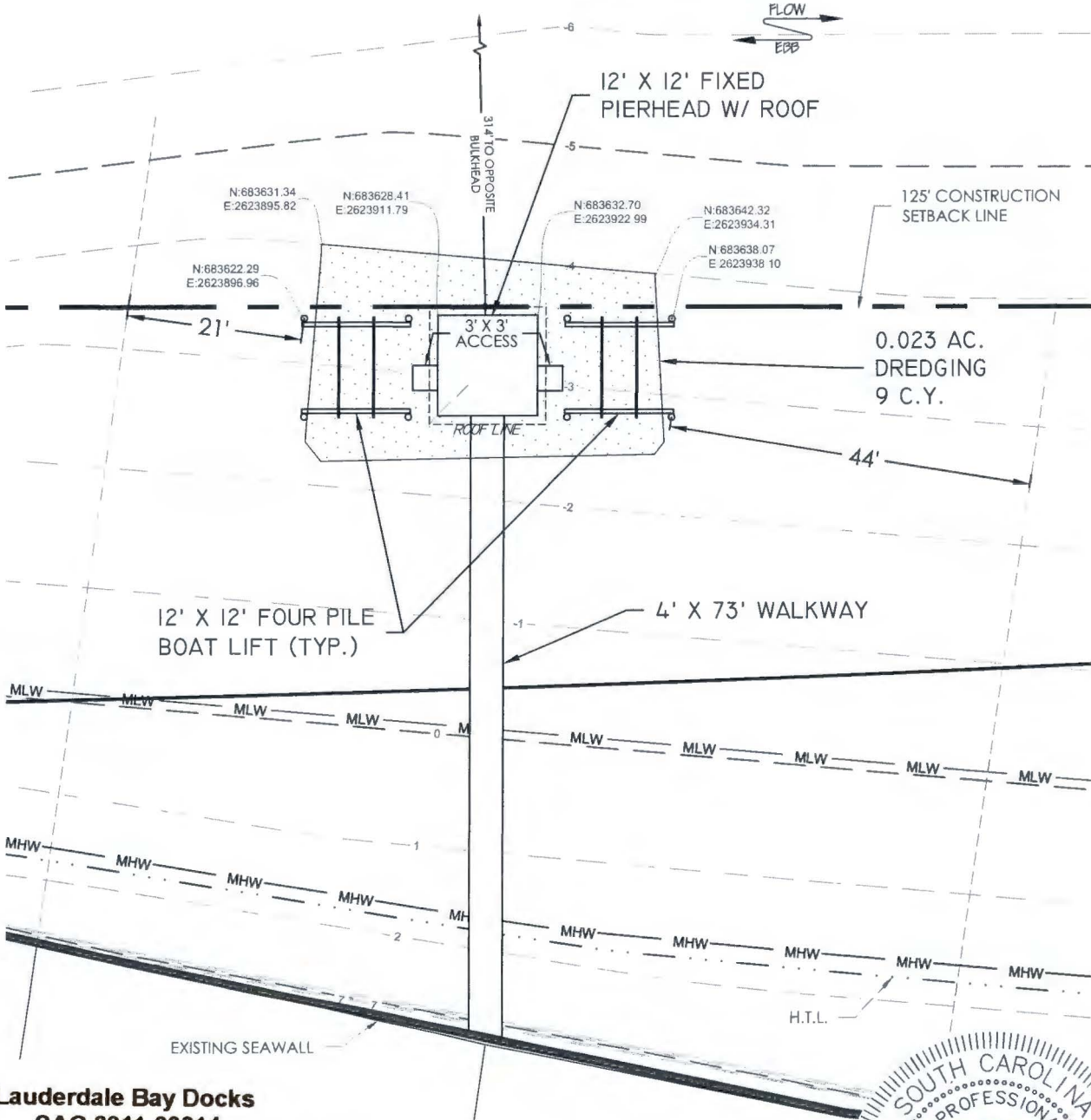

**Lauderdale Bay Docks**  
**SAC 2011-00314**  
**Horry County, South Carolina**  
**Dated: October 20, 2016**  
**Sheet 11 of 34**

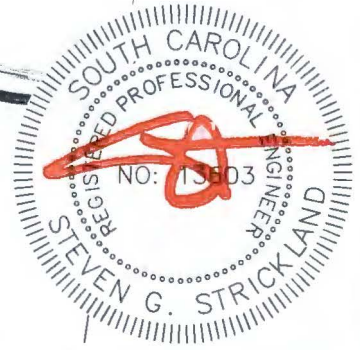

LOT 32

LOT 31

FOR PERMITTING PURPOSES ONLY - NOT FOR CONSTRUCTION

**EARTHWORKS**  
*planning and design consultants*  
 11655 HIGHWAY 707  
 MURRELLS INLET, SC 29576  
 phone - 843.651.7900  
 fax - 843.651.7903  
 earthworksgroup.com

**DOCK 5 - LOT 31 & 32**  
**PROPOSED**  
**LAUDERDALE BAY**  
 DOCK & DREDGE PERMITTING

SCALE  
 1" = 20'

APPLICANT: SALEM WOODS HOLDINGS, LLC  
 3306 GAITHER COURT  
 MYRTLE BEACH, SC 29588

LOCATION: US. HWY 17 BYPASS & LAUDERDALE BLVD.  
 HORRY COUNTY, SOUTH CAROLINA

LAT/LONG: 33.693733, -78.948624  
 USGS QUAD: MYRTLE BEACH

DATE: 12/12/16

TEG PN: 151096

SHEET  
**D5.2**



# DOCK 5

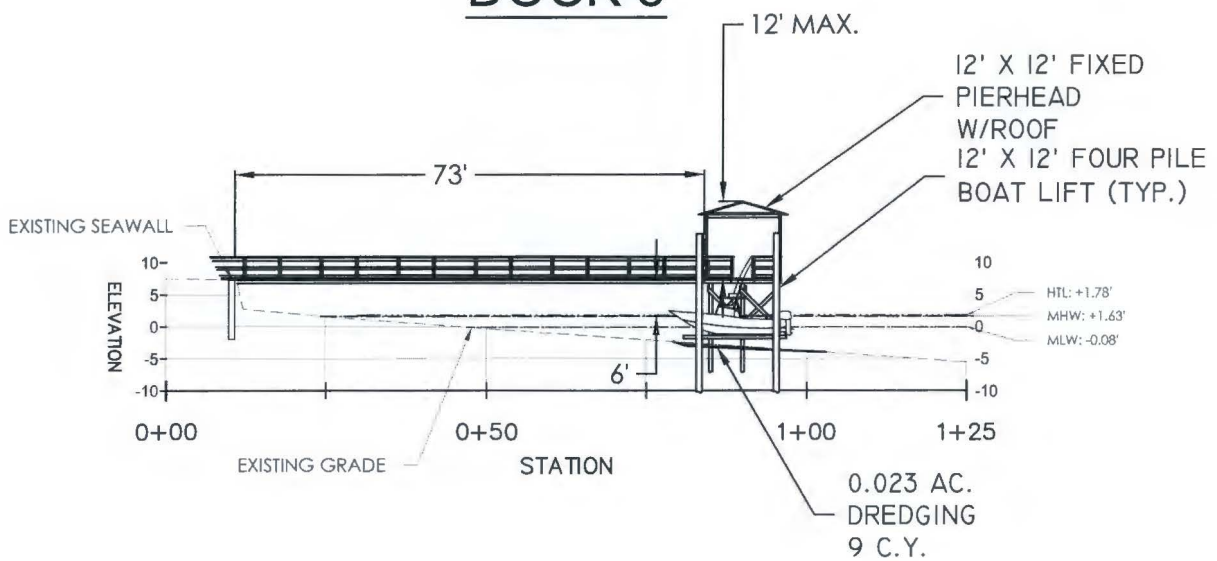

**Lauderdale Bay Docks**  
**SAC 2011-00314**  
**Horry County, South Carolina**  
**Dated: October 20, 2016**  
**Sheet 12 of 34**



ELEVATION DATUM: NAVD88

FOR PERMITTING PURPOSES ONLY - NOT FOR CONSTRUCTION

**EARTHWORKS**  
*planning and design consultants*  
 11655 HIGHWAY 707  
 MURRELLS INLET, SC 29576  
 phone - 843.651.7900  
 fax - 843.651.7903  
 earthworksgroup.com

**DOCK 5 - LOT 31 & 32**  
**PROFILE VIEW**  
 LAUDERDALE BAY  
 DOCK & DREDGE PERMITTING

0 15 30 SCALE 1" = 30'

APPLICANT: SALEM WOODS HOLDINGS, LLC  
 3306 GAITHER COURT  
 MYRTLE BEACH, SC 29588

LOCATION: US. HWY 17 BYPASS & LAUDERDALE BLVD.  
 HORRY COUNTY, SOUTH CAROLINA

LAT/LONG: 33.693733, -78.948624  
 USGS QUAD: MYRTLE BEACH

DATE: 12/12/16

TEG PN: 151096

**SHEET D5.3**



ATLANTIC INTRACOASTAL WATERWAY

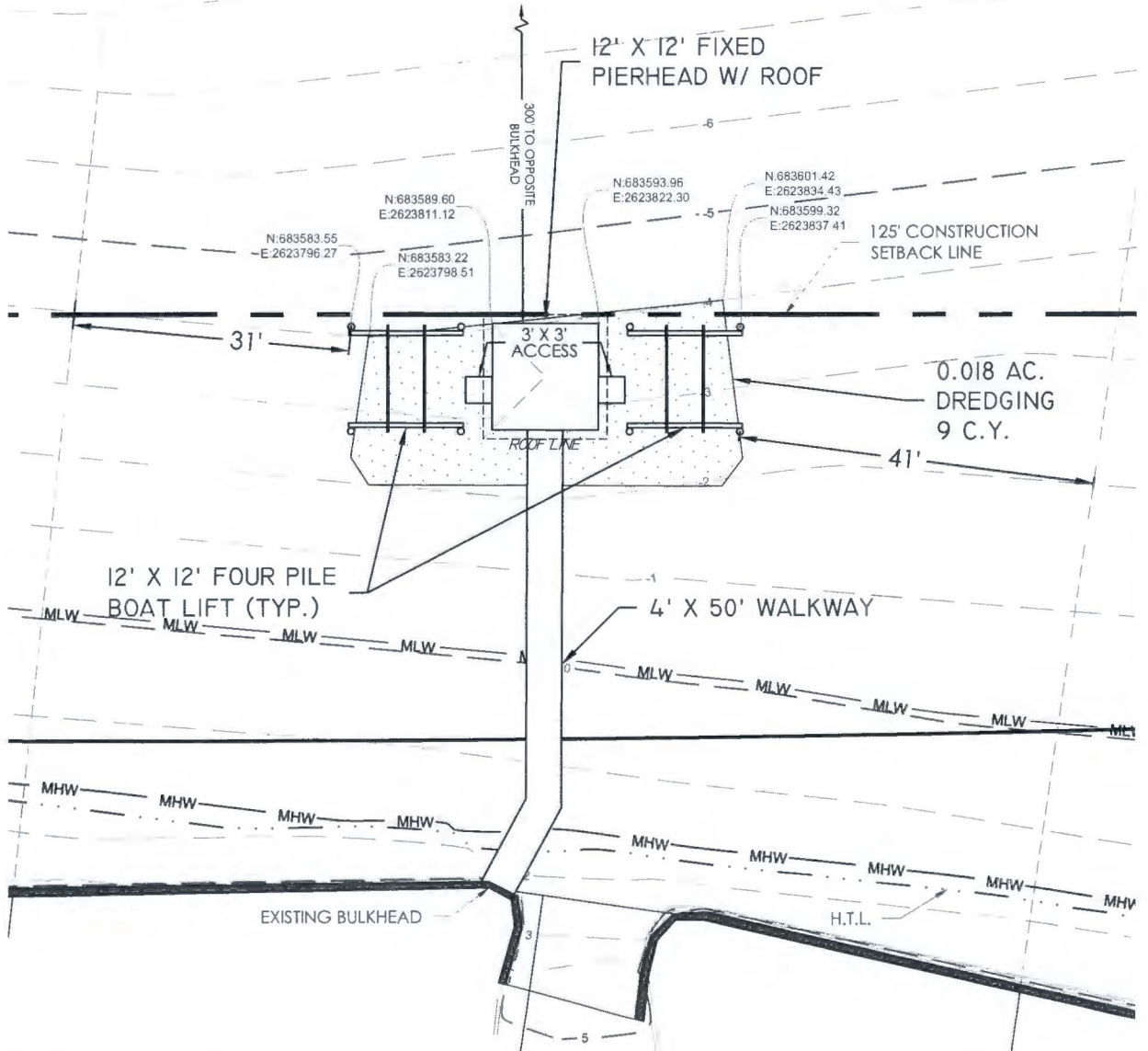
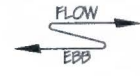

Lauderdale Bay Docks  
 SAC 2011-00314  
 Horry County, South Carolina  
 Dated: October 20, 2016  
 Sheet 13 of 34



LOT 34

LOT 33

FOR PERMITTING PURPOSES ONLY - NOT FOR CONSTRUCTION

**EARTHWORKS**  
 planning and design consultants  
 11655 HIGHWAY 707  
 MURRELLS INLET, SC 29576  
 phone - 843.651.7900  
 fax - 843.651.7903  
 earthworksgroup.com

**DOCK 6 - LOT 33 & 34**  
**PROPOSED**  
 LAUDERDALE BAY  
 DOCK & DREDGE PERMITTING

SCALE  
 1" = 20'

APPLICANT: SALEM WOODS HOLDINGS, LLC  
 3306 GAITHER COURT  
 MYRTLE BEACH, SC 29588

LOCATION: US, HWY 17 BYPASS & LAUDERDALE BLVD.  
 HORRY COUNTY, SOUTH CAROLINA

LAT/LONG: 33.693733, -78.948624  
 USGS QUAD: MYRTLE BEACH

DATE: 12/12/16

TEG PN: 151096

SHEET  
**D6.2**

# DOCK 6

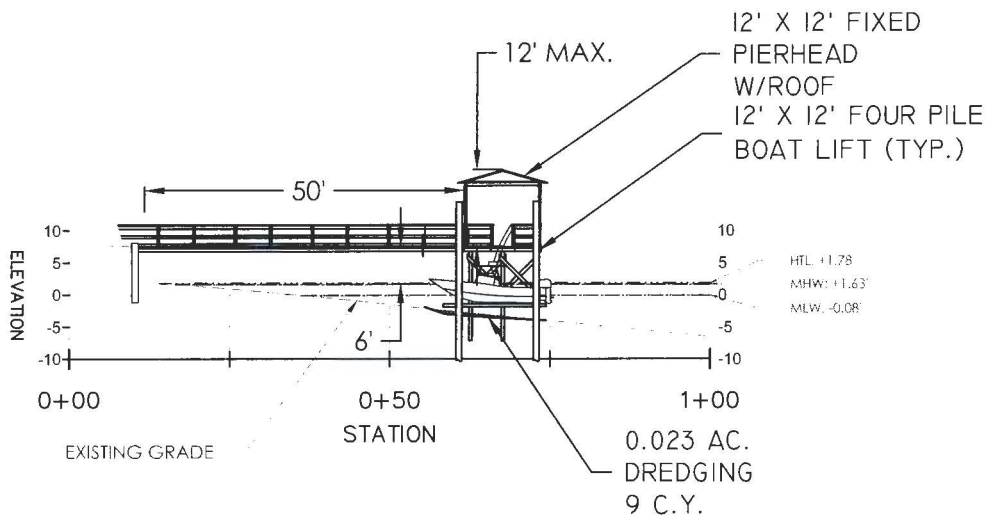

Lauderdale Bay Docks  
 SAC 2011-00314  
 Horry County, South Carolina  
 Dated: October 20, 2016  
 Sheet 14 of 34



ELEVATION DATUM: NAVD88

FOR PERMITTING PURPOSES ONLY - NOT FOR CONSTRUCTION

**EARTHWORKS**  
*planning and design consultants*

11655 HIGHWAY 707  
 MURRELLS INLET, SC 29576  
 phone - 843.651.7900  
 fax - 843.651.7903  
 earthworksgroup.com

**DOCK 6 - LOT 33 & 34**  
**PROFILE VIEW**  
 LAUDERDALE BAY  
 DOCK & DREDGE PERMITTING

0 15 30  
 SCALE  
 1" = 30'

APPLICANT: SALEM WOODS HOLDINGS, LLC  
 3306 GAITHER COURT  
 MYRTLE BEACH, SC 29588

LOCATION: US. HWY 17 BYPASS & LAUDERDALE BLVD.  
 HORRY COUNTY, SOUTH CAROLINA

LAT/LONG: 33.693733, -78.948624  
 USGS QUAD: MYRTLE BEACH

DATE: 12/12/16  
 TEG PN: 151096

SHEET  
**D6.3**

ATLANTIC INTRACOASTAL WATERWAY

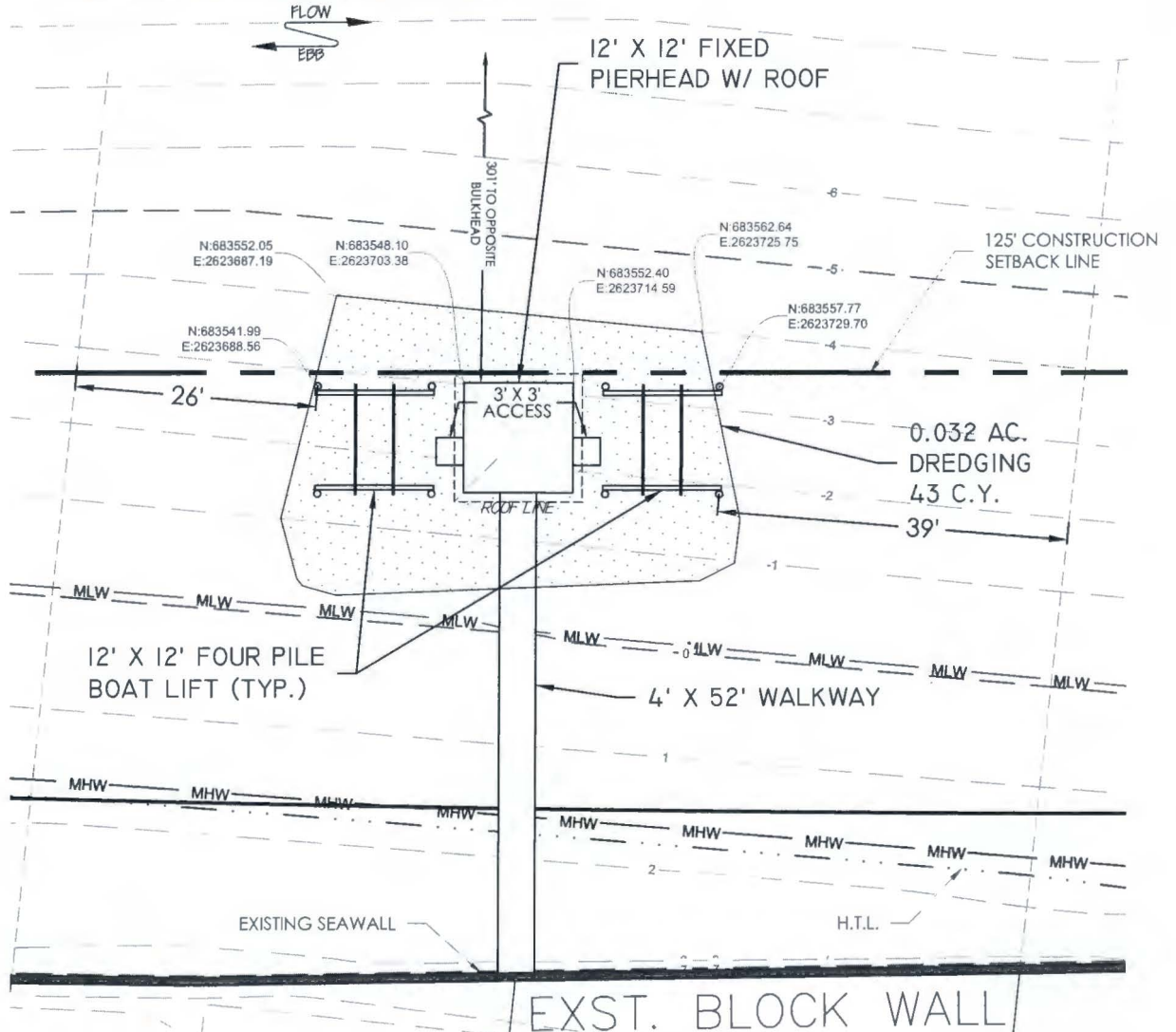

Lauderdale Bay Docks  
 SAC 2011-00314  
 Horry County, South Carolina  
 Dated: October 20, 2016  
 Sheet 15 of 34



LOT 36

LOT 35

FOR PERMITTING PURPOSES ONLY - NOT FOR CONSTRUCTION

**EARTHWORKS**  
 planning and design consultants  
 11655 HIGHWAY 707  
 MURRELLS INLET, SC 29576  
 phone - 843.651.7900  
 fax - 843.651.7903  
 earthworksgroup.com

**DOCK 7 - LOT 35 & 36**  
**PROPOSED**  
 LAUDERDALE BAY  
 DOCK & DREDGE PERMITTING

SCALE  
 1" = 20'

APPLICANT: SALEM WOODS HOLDINGS, LLC  
 3306 GAITHER COURT  
 MYRTLE BEACH, SC 29588

LOCATION: US, HWY 17 BYPASS & LAUDERDALE BLVD.  
 HORRY COUNTY, SOUTH CAROLINA

LAT/LONG: 33.693733, -78.948624  
 USGS QUAD: MYRTLE BEACH

DATE: 12/12/16

TEG PN: 151096

**SHEET**  
**D7.2**



# DOCK 7

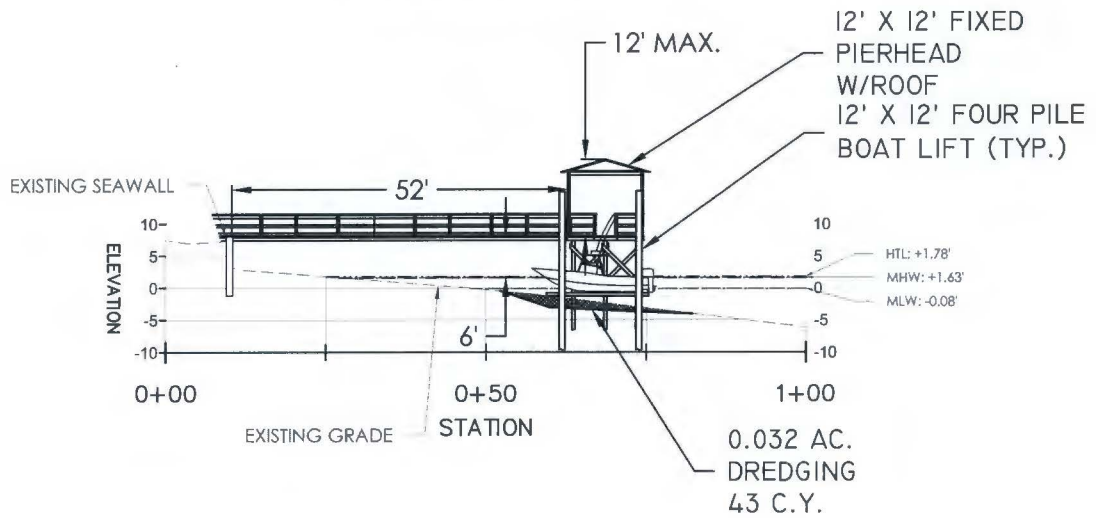

**Lauderdale Bay Docks**  
**SAC 2011-00314**  
**Horry County, South Carolina**  
**Dated: October 20, 2016**  
**Sheet 16 of 34**



ELEVATION DATUM: NAVD88

FOR PERMITTING PURPOSES ONLY - NOT FOR CONSTRUCTION

EARTHWORKS

*planning and design consultants*

11655 HIGHWAY 707  
 MURRELLS INLET, SC 29576  
 phone - 843.651.7900  
 fax - 843.651.7903  
 earthworksgroup.com

DOCK 7 - LOT 35 & 36

PROFILE VIEW

LAUDERDALE BAY

DOCK & DREDGE PERMITTING

SCALE  
1" = 30'

APPLICANT: SALEM WOODS HOLDINGS, LLC  
 3306 GAITHER COURT  
 MYRTLE BEACH, SC 29588

LOCATION: US. HWY 17 BYPASS & LAUDERDALE BLVD.  
 HORRY COUNTY, SOUTH CAROLINA

LAT/LONG: 33.693733, -78.948624  
 USGS QUAD: MYRTLE BEACH

DATE: 12/12/16

SHEET  
**D7.3**

TEG PN: 151096

ATLANTIC INTRACOASTAL WATERWAY

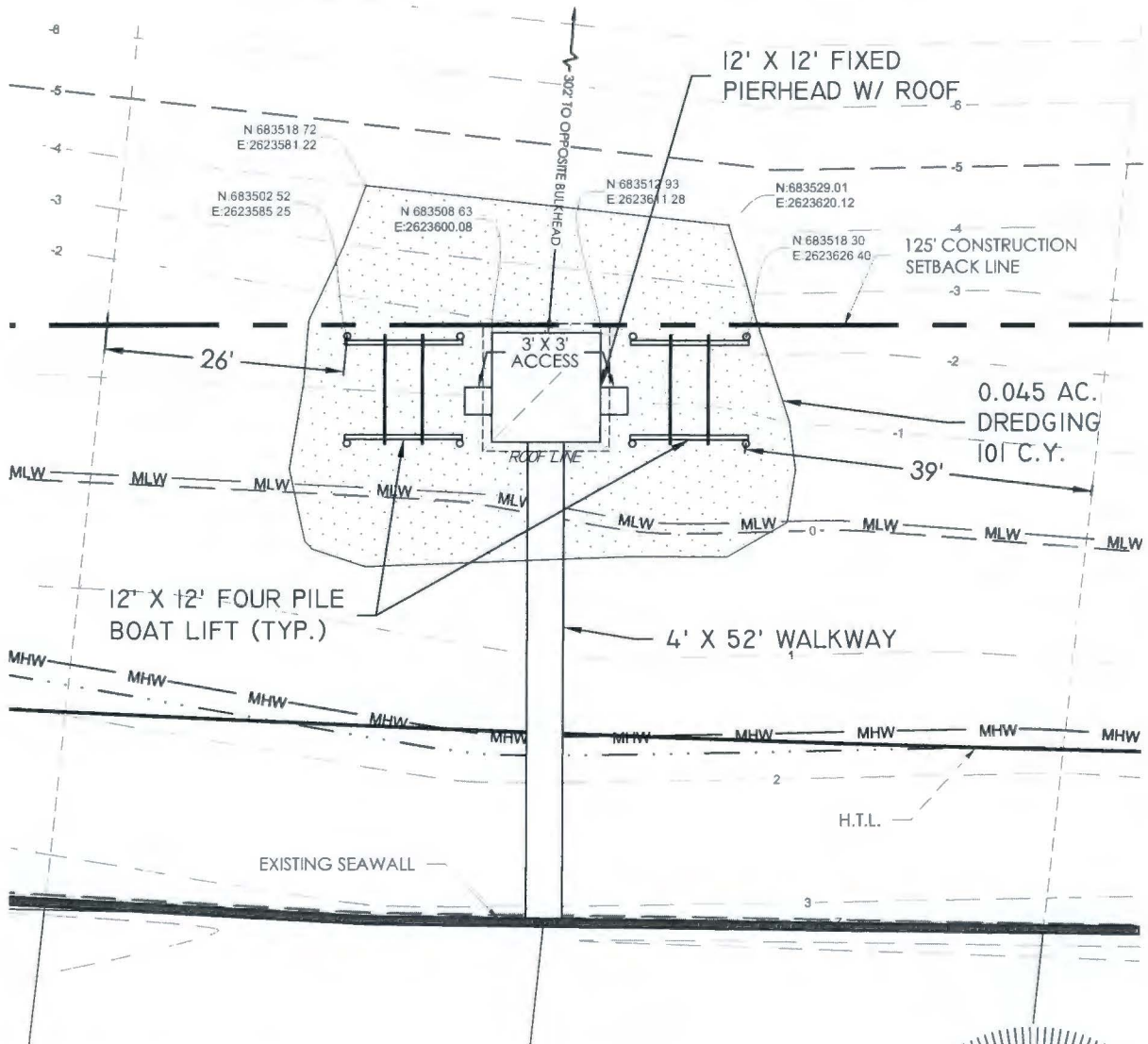
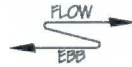

Lauderdale Bay Docks  
 SAC 2011-00314  
 Horry County, South Carolina  
 Dated: October 20, 2016  
 Sheet 17 of 34

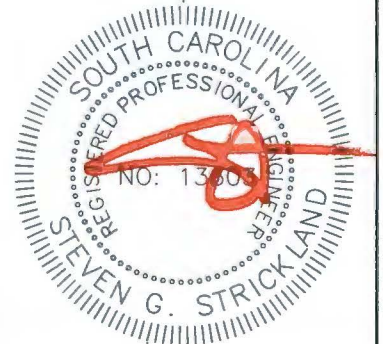

LOT 38

LOT 37

FOR PERMITTING PURPOSES ONLY - NOT FOR CONSTRUCTION

**EARTHWORKS**  
 planning and design consultants  
 11655 HIGHWAY 707  
 MURRELLS INLET, SC 29576  
 phone - 843.651.7900  
 fax - 843.651.7903  
 earthworksgroup.com

**DOCK 8 - LOT 37 & 38**  
**PROPOSED**  
 LAUDERDALE BAY  
 DOCK & DREDGE PERMITTING

SCALE  
 1" = 20'

APPLICANT: SALEM WOODS HOLDINGS, LLC  
 3306 GAITHER COURT  
 MYRTLE BEACH, SC 29588

LOCATION: US, HWY 17 BYPASS & LAUDERDALE BLVD.  
 HORRY COUNTY, SOUTH CAROLINA

LAT/LONG: 33.693733, -78.948624  
 USGS QUAD: MYRTLE BEACH

DATE: 12/12/16

TEG PN: 151096

SHEET  
**D8.2**

# DOCK 8

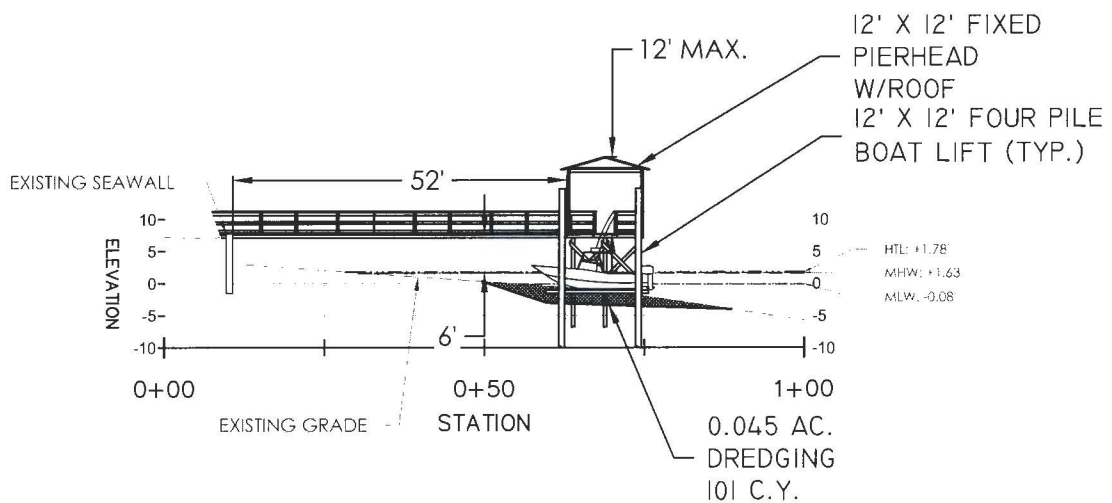

**Lauderdale Bay Docks**  
**SAC 2011-00314**  
**Horry County, South Carolina**  
**Dated: October 20, 2016**  
**Sheet 18 of 34**



ELEVATION DATUM: NAVD88

FOR PERMITTING PURPOSES ONLY - NOT FOR CONSTRUCTION

**EARTHWORKS**  
*planning and design consultants*

11655 HIGHWAY 707  
 MURRELLS INLET, SC 29576  
 phone - 843.651.7900  
 fax - 843.651.7903  
 earthworksgroup.com

**DOCK 8 - LOT 37 & 38**  
**PROFILE VIEW**  
 LAUDERDALE BAY  
 DOCK & DREDGE PERMITTING

0 15 30 SCALE 1" = 30'

APPLICANT: SALEM WOODS HOLDINGS, LLC  
 3306 GAITHER COURT  
 MYRTLE BEACH, SC 29588

LOCATION: US. HWY 17 BYPASS & LAUDERDALE BLVD.  
 HORRY COUNTY, SOUTH CAROLINA

LAT/LONG: 33.693733, -78.948624  
 USGS QUAD: MYRTLE BEACH

DATE: 12/12/16  
 TEG PN: 151096

**SHEET D8.3**



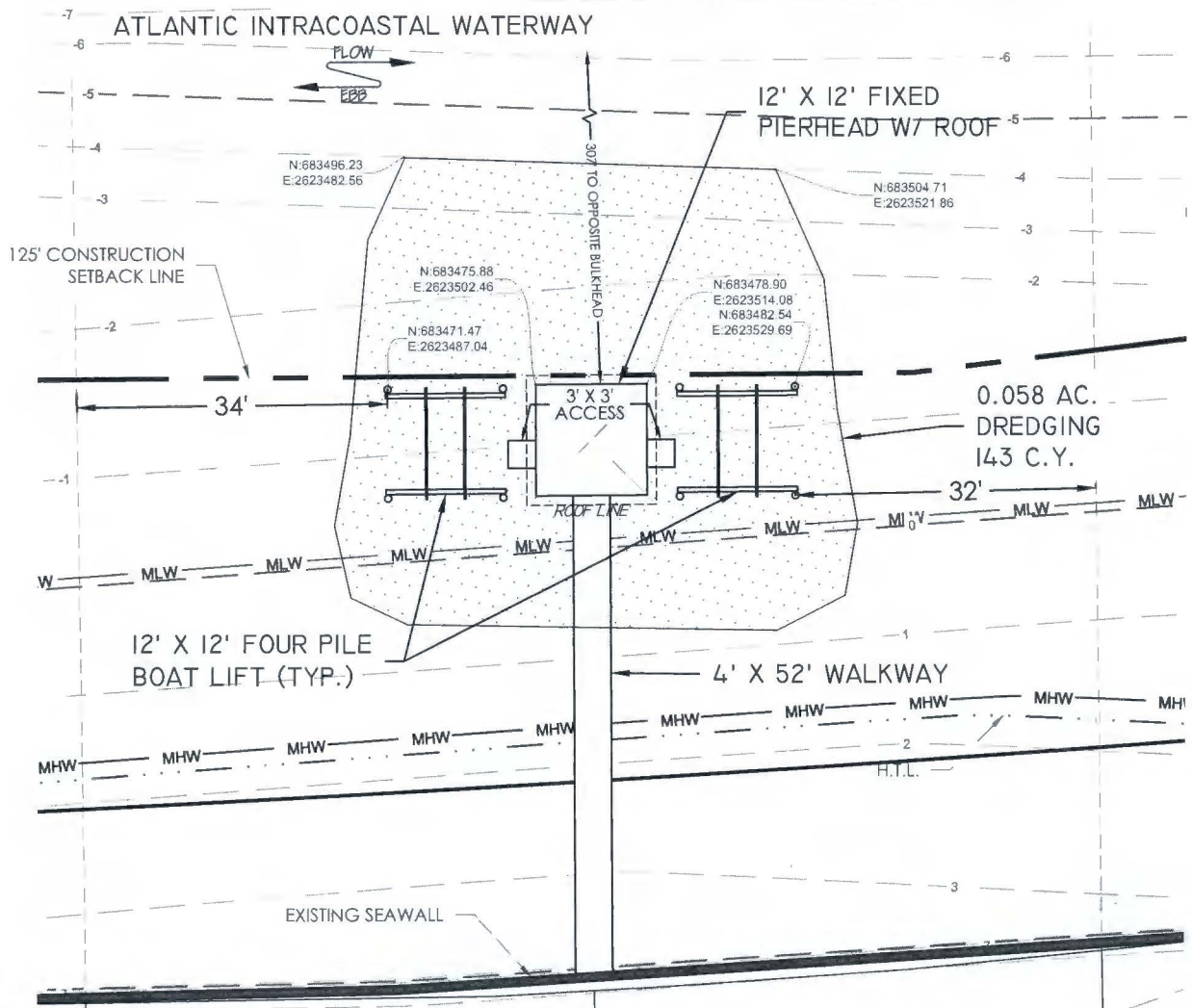

Lauderdale Bay Docks  
 SAC 2011-00314  
 Horry County, South Carolina  
 Dated: October 20, 2016  
 Sheet 19 of 34



LOT 40

LOT 39

FOR PERMITTING PURPOSES ONLY - NOT FOR CONSTRUCTION

**EARTHWORKS**  
 planning and design consultants  
 11655 HIGHWAY 707  
 MURRELLS INLET, SC 29576  
 phone - 843.651.7900  
 fax - 843.651.7903  
 earthworksgroup.com

**DOCK 9 - LOT 39 & 40**  
**PROPOSED**  
 LAUDERDALE BAY  
 DOCK & DREDGE PERMITTING

SCALE  
 1" = 20'

APPLICANT: SALEM WOODS HOLDINGS, LLC  
 3306 GAITHER COURT  
 MYRTLE BEACH, SC 29588

LOCATION: US, HWY 17 BYPASS & LAUDERDALE BLVD.  
 HORRY COUNTY, SOUTH CAROLINA  
 LAT/LONG: 33.693733, -78.948624  
 USGS QUAD: MYRTLE BEACH

DATE: 12/12/16  
 TEG PN: 151096

SHEET  
**D9.2**



# DOCK 9

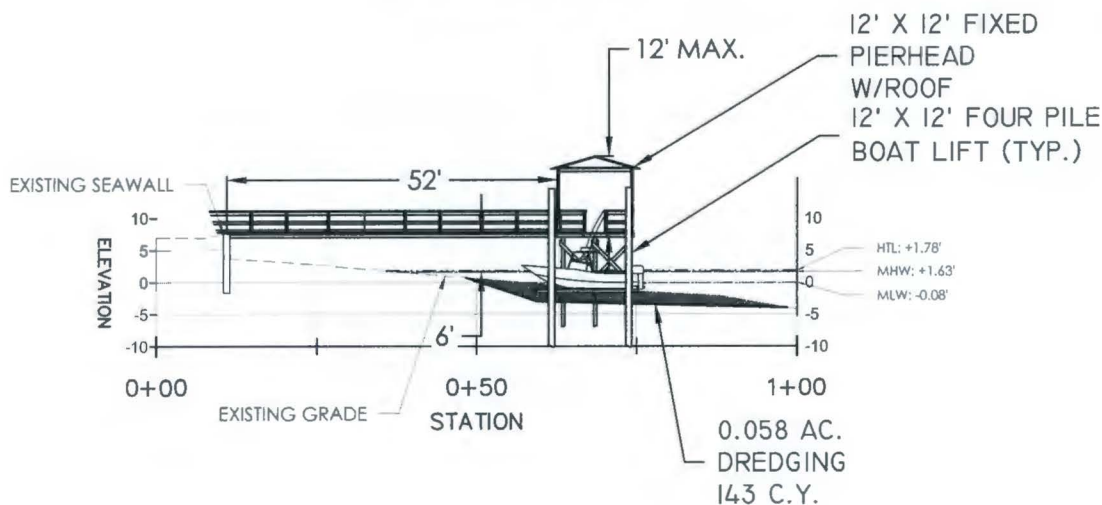

**Lauderdale Bay Docks**  
**SAC 2011-00314**  
**Horry County, South Carolina**  
**Dated: October 20, 2016**  
**Sheet 20 of 34**



ELEVATION DATUM: NAVD88

FOR PERMITTING PURPOSES ONLY - NOT FOR CONSTRUCTION

**EARTHWORKS**  
*planning and design consultants*  
 11655 HIGHWAY 707  
 MURRELLS INLET, SC 29576  
 phone - 843.651.7900  
 fax - 843.651.7903  
 earthworksgroup.com

**DOCK 9 - LOT 39 & 40**  
**PROFILE VIEW**  
 LAUDERDALE BAY  
 DOCK & DREDGE PERMITTING

SCALE  
 1" = 30'

APPLICANT: SALEM WOODS HOLDINGS, LLC  
 3306 GAITHER COURT  
 MYRTLE BEACH, SC 29588

LOCATION: US, HWY 17 BYPASS & LAUDERDALE BLVD.  
 HORRY COUNTY, SOUTH CAROLINA  
 LAT/LONG: 33.693733, -78.948624  
 USGS QUAD: MYRTLE BEACH

DATE: 12/12/16

TEG PN: 151096

SHEET  
**D9.3**

ATLANTIC INTRACOASTAL WATERWAY

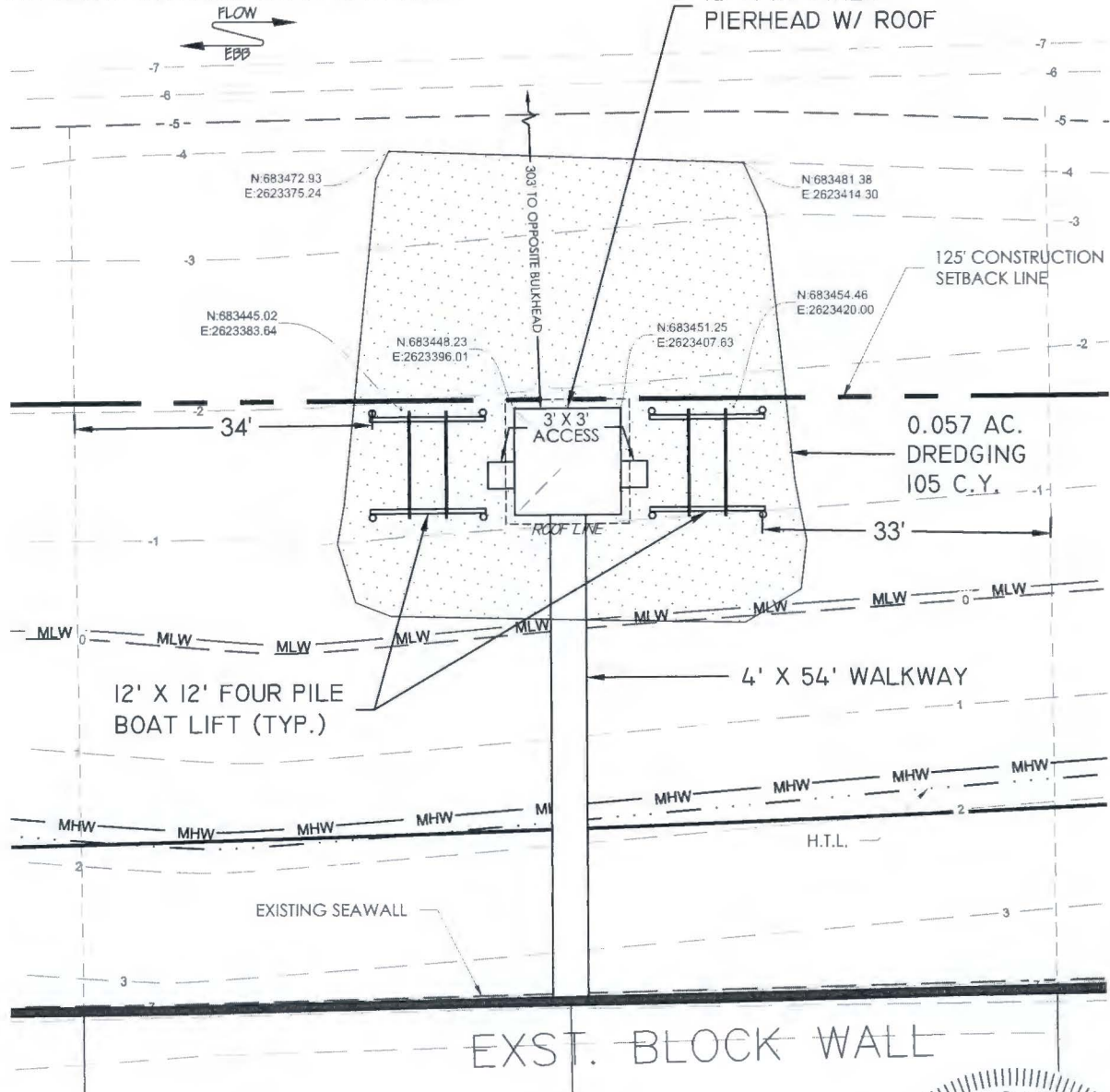

Lauderdale Bay Docks  
 SAC 2011-00314  
 Horry County, South Carolina  
 Dated: October 20, 2016  
 Sheet 21 of 34

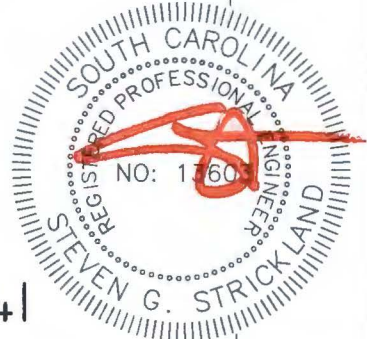

LOT 42

LOT 41

FOR PERMITTING PURPOSES ONLY - NOT FOR CONSTRUCTION

**EARTHWORKS**  
 planning and design consultants  
 11655 HIGHWAY 707  
 MURRELLS INLET, SC 29576  
 phone - 843.651.7900  
 fax - 843.651.7903  
 earthworksgroup.com

**DOCK 10 - LOT 41 & 42**  
**PROPOSED**  
 LAUDERDALE BAY  
 DOCK & DREDGE PERMITTING

SCALE  
 1" = 20'

APPLICANT: SALEM WOODS HOLDINGS, LLC  
 3306 GAITHER COURT  
 MYRTLE BEACH, SC 29588

LOCATION: US, HWY 17 BYPASS & LAUDERDALE BLVD.  
 HORRY COUNTY, SOUTH CAROLINA  
 LAT/LONG: 33.693733, -78.948624  
 USGS QUAD: MYRTLE BEACH

DATE: 12/12/16  
 TEG PN: 151096

SHEET  
**D10.2**

# DOCK 10

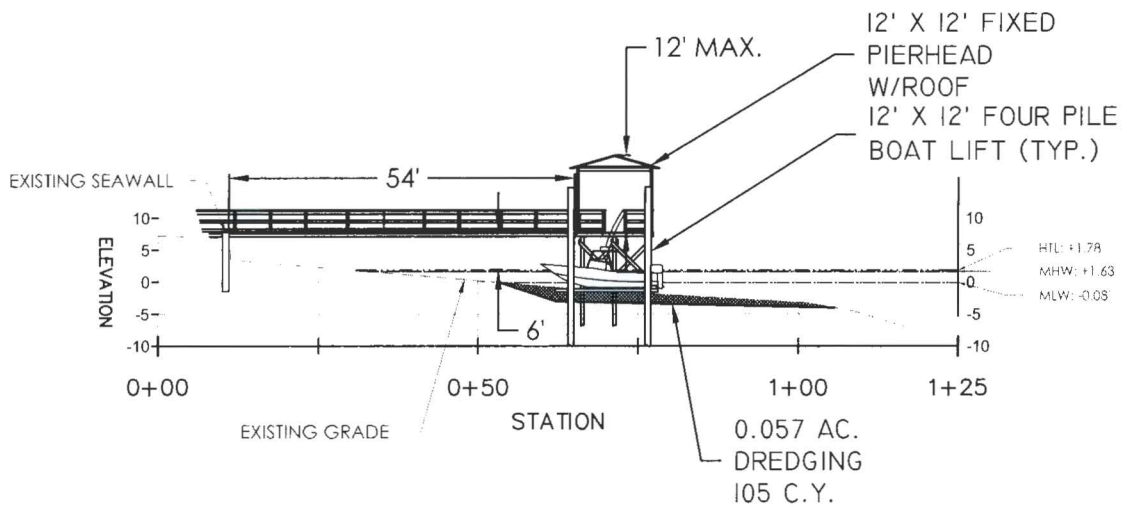

**Lauderdale Bay Docks**  
**SAC 2011-00314**  
**Horry County, South Carolina**  
**Dated: October 20, 2016**  
**Sheet 22 of 34**



ELEVATION DATUM: NAVD88

FOR PERMITTING PURPOSES ONLY - NOT FOR CONSTRUCTION

**EARTHWORKS**  
*planning and design consultants*

11655 HIGHWAY 707  
 MURRELLS INLET, SC 29576  
 phone - 843.651.7900  
 fax - 843.651.7903  
 earthworksgroup.com

**DOCK 10 - LOT 41 & 42**  
**PROFILE VIEW**  
 LAUDERDALE BAY  
 DOCK & DREDGE PERMITTING

0 15 30 SCALE 1" = 30'

APPLICANT: SALEM WOODS HOLDINGS, LLC  
 3306 GAITHER COURT  
 MYRTLE BEACH, SC 29588

LOCATION: US, HWY 17 BYPASS & LAUDERDALE BLVD.  
 HORRY COUNTY, SOUTH CAROLINA  
 LAT/LONG: 33.693733, -78.948624  
 USGS QUAD: MYRTLE BEACH

DATE: 12/12/16

SHEET **D10.3**



ATLANTIC INTRACOASTAL WATERWAY

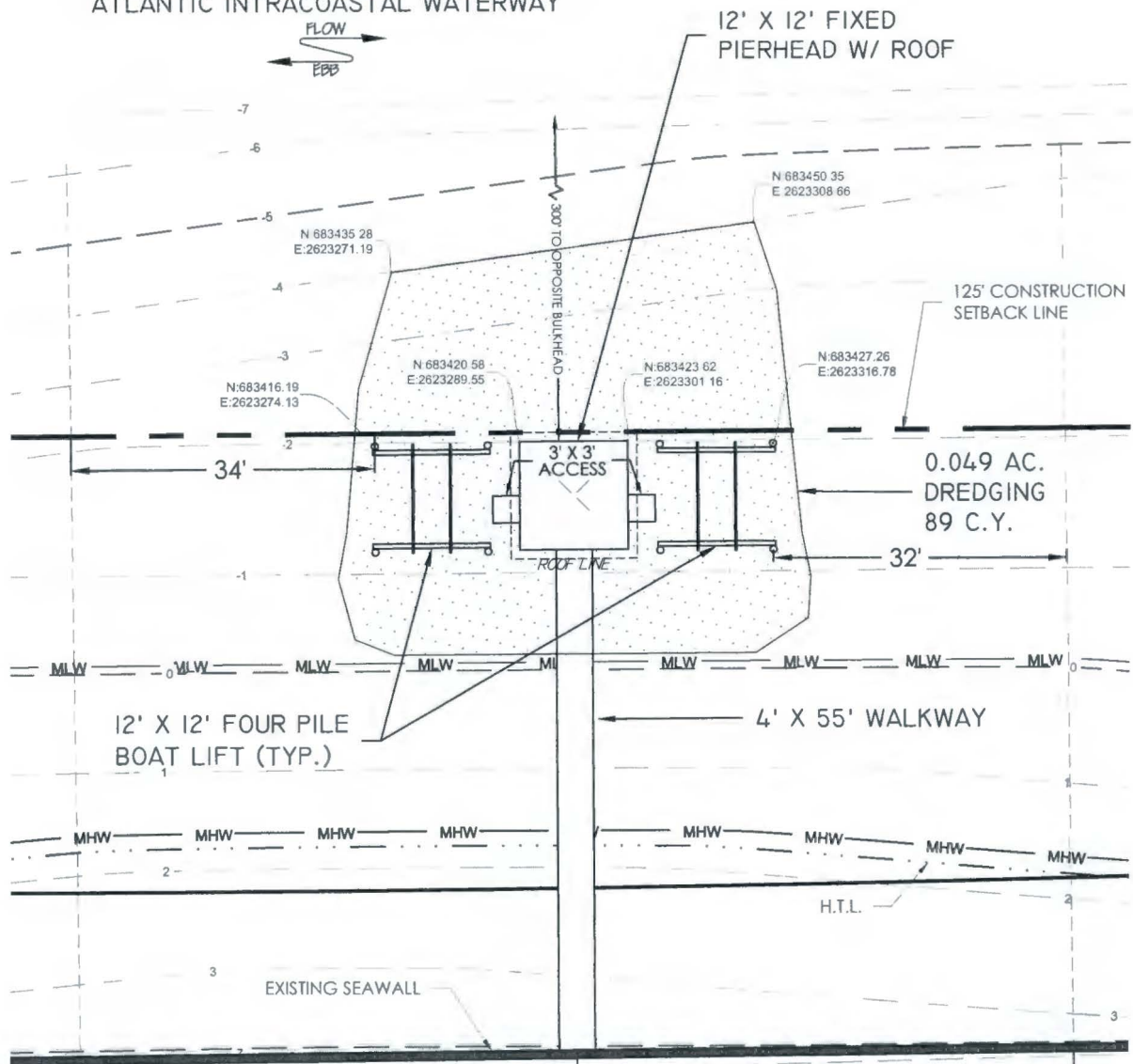

Lauderdale Bay Docks  
 SAC 2011-00314  
 Horry County, South Carolina  
 Dated: October 20, 2016  
 Sheet 23 of 34

LOT 44

LOT 43

FOR PERMITTING PURPOSES ONLY - NOT FOR CONSTRUCTION

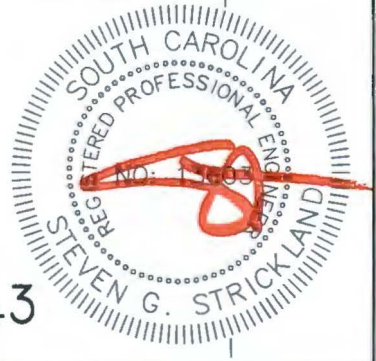

**EARTHWORKS**  
 planning and design consultants

11655 HIGHWAY 707  
 MURRELLS INLET, SC 29576  
 phone - 843.651.7900  
 fax - 843.651.7903  
 earthworksgroup.com

**DOCK 11 - LOT 43 & 44**  
**PROPOSED**  
 LAUDERDALE BAY  
 DOCK & DREDGE PERMITTING

0 10 20  
 SCALE  
 1" = 20'

APPLICANT: SALEM WOODS HOLDINGS, LLC  
 3306 GAITHER COURT  
 MYRTLE BEACH, SC 29588

LOCATION: US. HWY 17 BYPASS & LAUDERDALE BLVD.  
 HORRY COUNTY, SOUTH CAROLINA  
 LAT/LONG: 33.693733, -78.948624  
 USGS QUAD: MYRTLE BEACH

DATE: 12/12/16

REG. NO: 11505

STEVEN G. STRICKLAND

SHEET  
**D11.2**

TEG PN: 151096

# DOCK 11

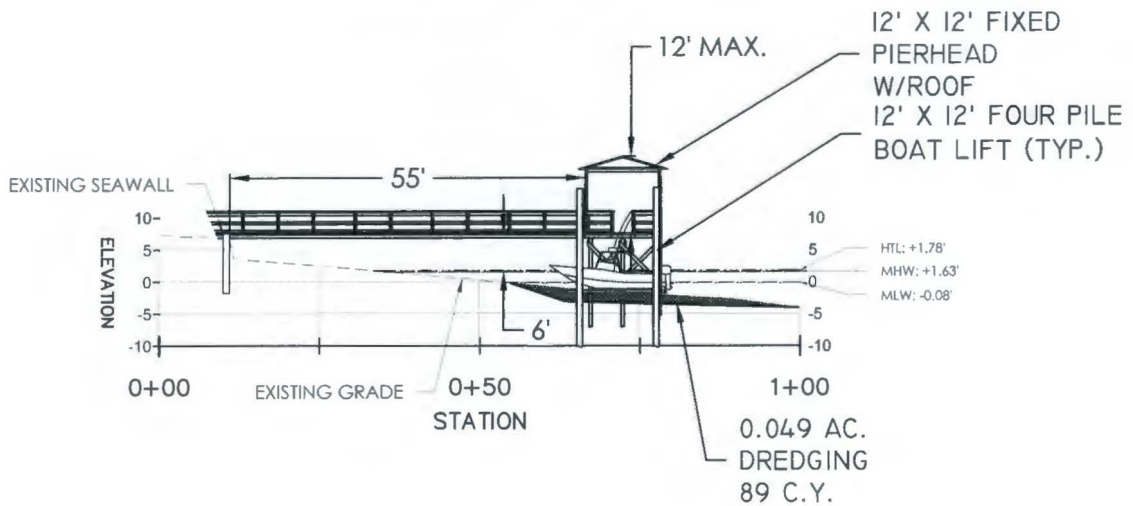

**Lauderdale Bay Docks**  
**SAC 2011-00314**  
**Horry County, South Carolina**  
**Dated: October 20, 2016**  
**Sheet 24 of 34**

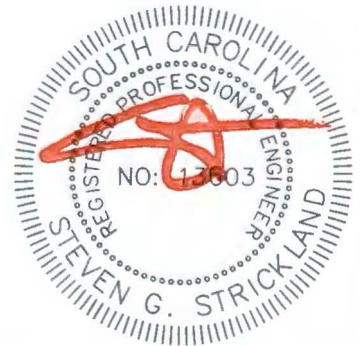

ELEVATION DATUM: NAVD88

FOR PERMITTING PURPOSES ONLY - NOT FOR CONSTRUCTION



**EARTHWORKS**  
*planning and design consultants*

11655 HIGHWAY 707  
 MURRELLS INLET, SC 29576  
 phone - 843.651.7900  
 fax - 843.651.7903  
 earthworksgroup.com

**DOCK 11 - LOT 43 & 44**

**PROFILE VIEW**

LAUDERDALE BAY  
 DOCK & DREDGE PERMITTING



 SCALE  
 1" = 30'

APPLICANT: SALEM WOODS HOLDINGS, LLC  
 3306 GAITHER COURT  
 MYRTLE BEACH, SC 29588

LOCATION: US. HWY 17 BYPASS & LAUDERDALE BLVD.  
 HORRY COUNTY, SOUTH CAROLINA

LAT/LONG: 33.693733, -78.948624  
 USGS QUAD: MYRTLE BEACH

DATE: 12/12/16

SHEET  
**D11.3**

TEG PN: 151096

ATLANTIC INTRACOASTAL WATERWAY

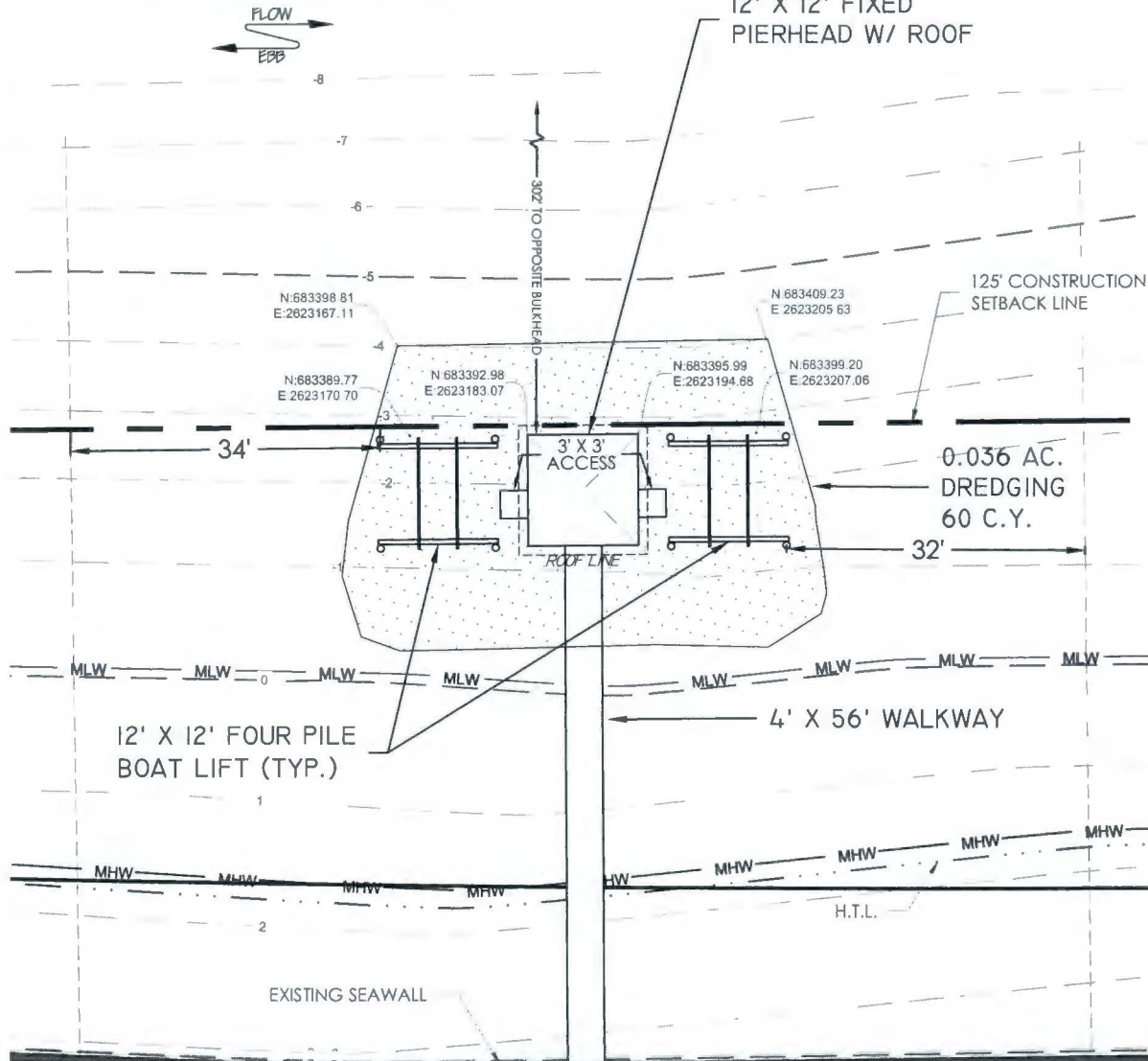

Lauderdale Bay Docks  
 SAC 2011-00314  
 Horry County, South Carolina  
 Dated: October 20, 2016  
 Sheet 25 of 34

LOT 46

LOT 45

FOR PERMITTING PURPOSES ONLY - NOT FOR CONSTRUCTION

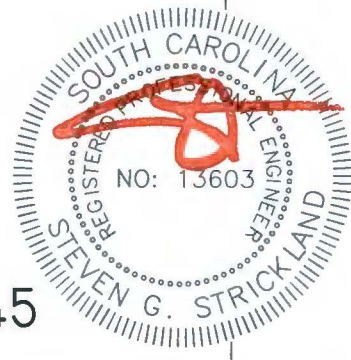

**EARTHWORKS**  
 planning and design consultants  
 11655 HIGHWAY 707  
 MURRELLS INLET, SC 29576  
 phone - 843.651.7900  
 fax - 843.651.7903  
 earthworksgroup.com

**DOCK 12 - LOT 45 & 46**  
**PROPOSED**  
 LAUDERDALE BAY  
 DOCK & DREDGE PERMITTING

0 10 20  
 SCALE  
 1" = 20'

APPLICANT: SALEM WOODS HOLDINGS, LLC  
 3306 GAITHER COURT  
 MYRTLE BEACH, SC 29588

LOCATION: US, HWY 17 BYPASS & LAUDERDALE BLVD.  
 HORRY COUNTY, SOUTH CAROLINA  
 LAT/LONG: 33.693733, -78.948624  
 USGS QUAD: MYRTLE BEACH

DATE: 12/12/16

REG. NO. 13603

STEVEN G. STRICKLAND

SHEET  
**D12.2**

TEG PN: 151096



# DOCK 12

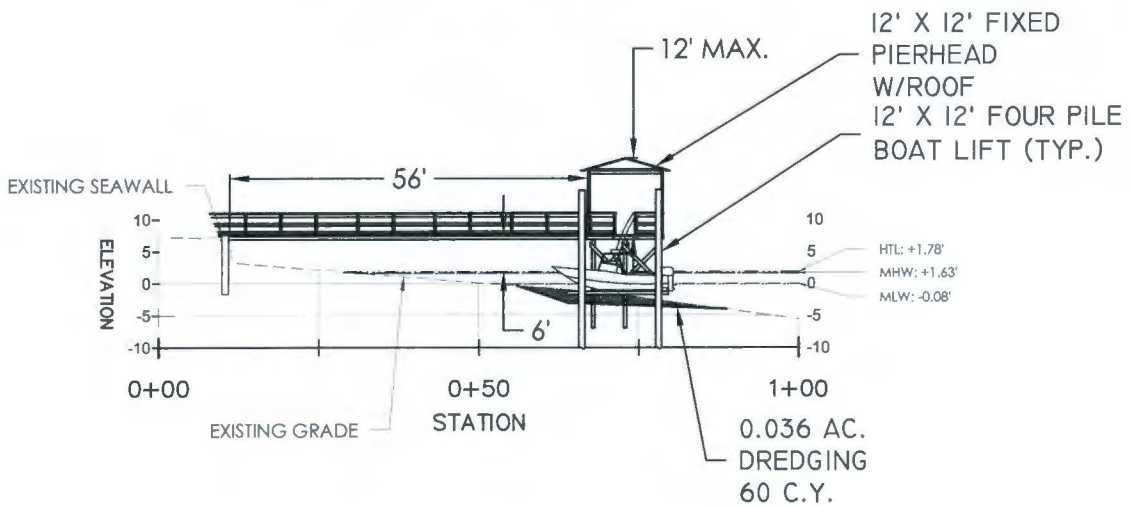

**Lauderdale Bay Docks**  
**SAC 2011-00314**  
**Horry County, South Carolina**  
**Dated: October 20, 2016**  
**Sheet 26 of 34**

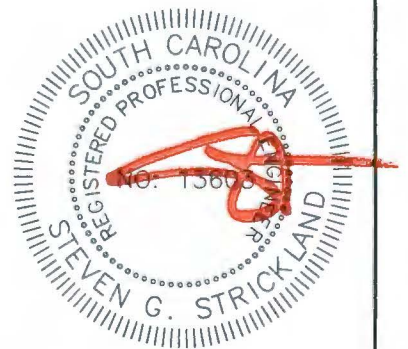

ELEVATION DATUM: NAVD88



FOR PERMITTING PURPOSES ONLY - NOT FOR CONSTRUCTION

**EARTHWORKS**  
*planning and design consultants*

11655 HIGHWAY 707  
 MURRELLS INLET, SC 29576  
 phone - 843.651.7900  
 fax - 843.651.7903  
 earthworksgroup.com

**DOCK 12 - LOT 45 & 46**

**PROFILE VIEW**  
 LAUDERDALE BAY  
 DOCK & DREDGE PERMITTING



 SCALE  
 1" = 30'

APPLICANT: SALEM WOODS HOLDINGS, LLC  
 3306 GAITHER COURT  
 MYRTLE BEACH, SC 29588

LOCATION: US. HWY 17 BYPASS & LAUDERDALE BLVD.  
 HORRY COUNTY, SOUTH CAROLINA

LAT/LONG: 33.693733, -78.948624  
 USGS QUAD: MYRTLE BEACH

DATE: 12/12/16

SHEET  
**D12.3**

TEG PN: 151096



ATLANTIC INTRACOASTAL WATERWAY



12' X 12' FIXED  
PIERHEAD W/ ROOF

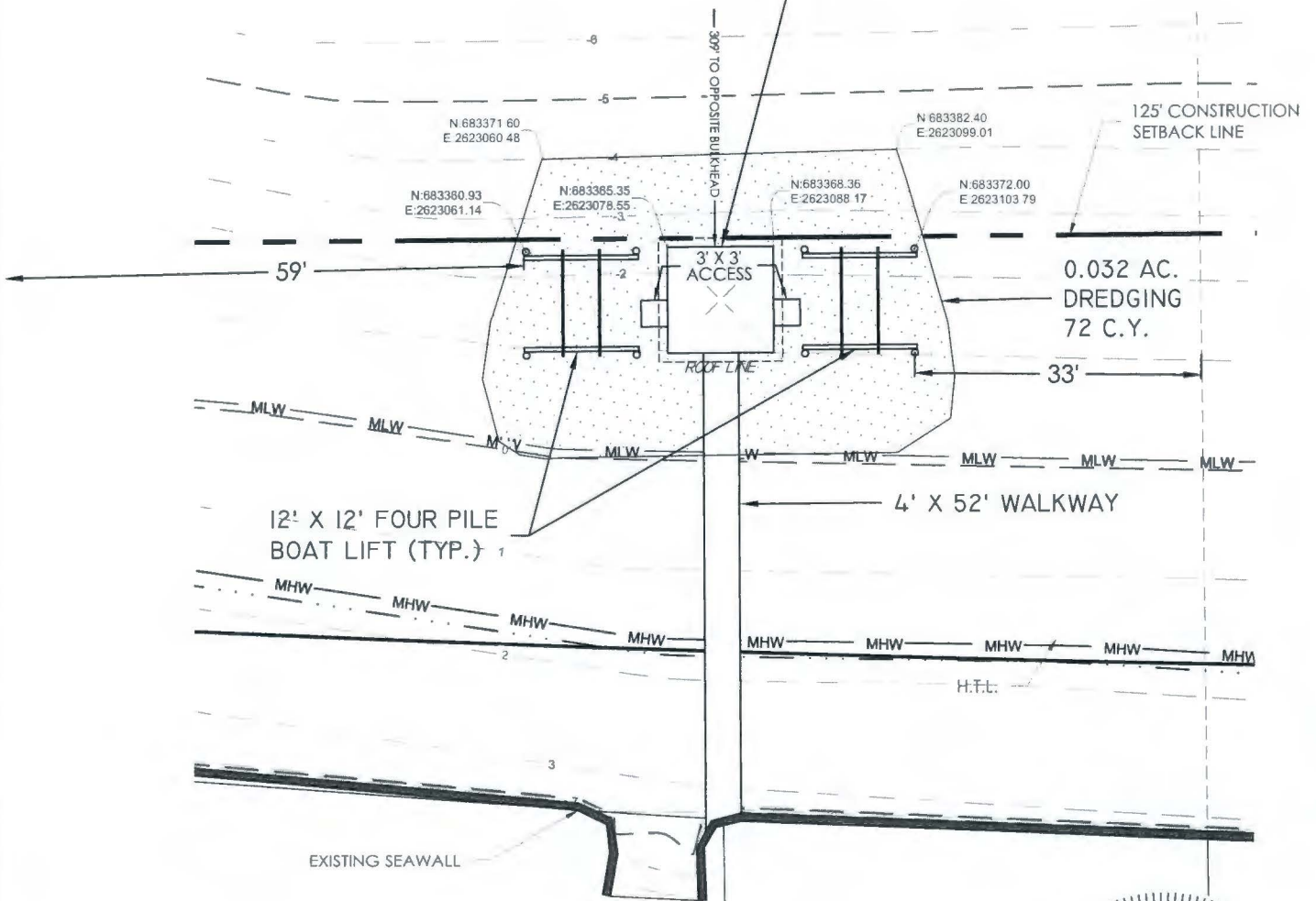

Lauderdale Bay Docks  
SAC 2011-00314  
Horry County, South Carolina  
Dated: October 20, 2016  
Sheet 27 of 34



LOT 48

LOT 47

FOR PERMITTING PURPOSES ONLY - NOT FOR CONSTRUCTION

**EARTHWORKS**  
planning and design consultants  
11655 HIGHWAY 707  
MURRELLS INLET, SC 29576  
phone - 843.651.7900  
fax - 843.651.7903  
earthworksgroup.com

**DOCK 13 - LOT 47 & 48**  
**PROPOSED**  
LAUDERDALE BAY  
DOCK & DREDGE PERMITTING

SCALE  
1" = 20'

APPLICANT: SALEM WOODS HOLDINGS, LLC  
3306 GAITHER COURT  
MYRTLE BEACH, SC 29588

LOCATION: US. HWY 17 BYPASS & LAUDERDALE BLVD.  
HORRY COUNTY, SOUTH CAROLINA  
LAT/LONG: 33.693733, -78.948624  
USGS QUAD: MYRTLE BEACH

DATE: 12/12/16

TEG PN: 151096

SHEET  
**D13.2**

# DOCK 13

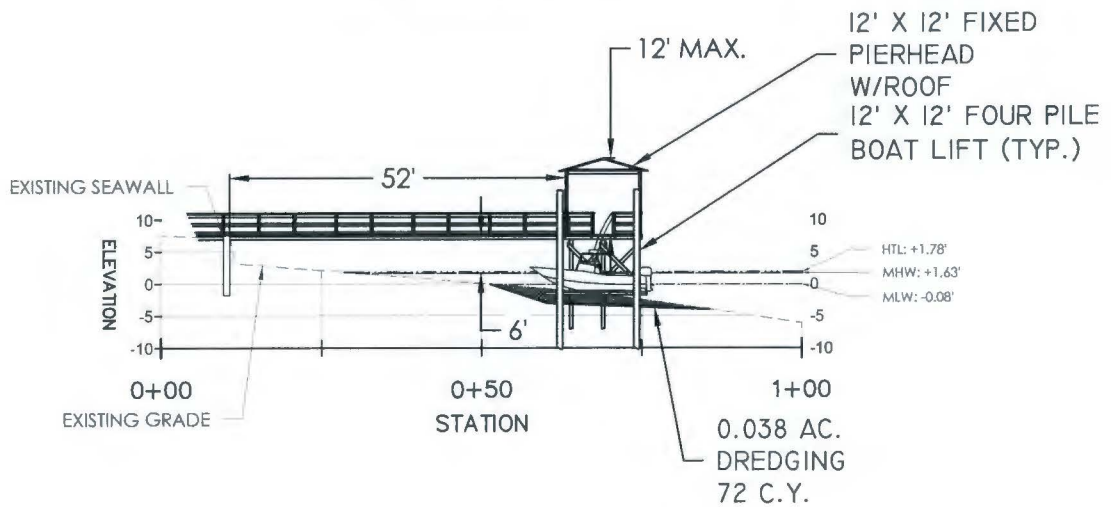

**Lauderdale Bay Docks**  
**SAC 2011-00314**  
**Horry County, South Carolina**  
**Dated: October 20, 2016**  
**Sheet 28 of 34**

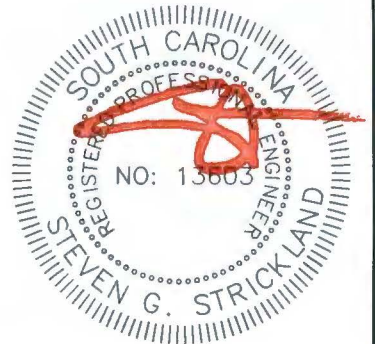

ELEVATION DATUM: NAVD88

FOR PERMITTING PURPOSES ONLY - NOT FOR CONSTRUCTION

**EARTHWORKS**  
*planning and design consultants*

11655 HIGHWAY 707  
MURRELLS INLET, SC 29576  
phone - 843.651.7900  
fax - 843.651.7903  
earthworksgroup.com

**DOCK 13 - LOT 47 & 48**  
**PROFILE VIEW**  
**LAUDERDALE BAY**  
DOCK & DREDGE PERMITTING

0 15 30 SCALE 1" = 30'

APPLICANT: SALEM WOODS HOLDINGS, LLC  
3306 GAITHER COURT  
MYRTLE BEACH, SC 29588

LOCATION: US, HWY 17 BYPASS & LAUDERDALE BLVD.  
HORRY COUNTY, SOUTH CAROLINA

LAT/LONG: 33.693733, -78.948624  
USGS QUAD: MYRTLE BEACH

DATE: 12/12/16

TEG PN: 151096

**SHEET D13.3**

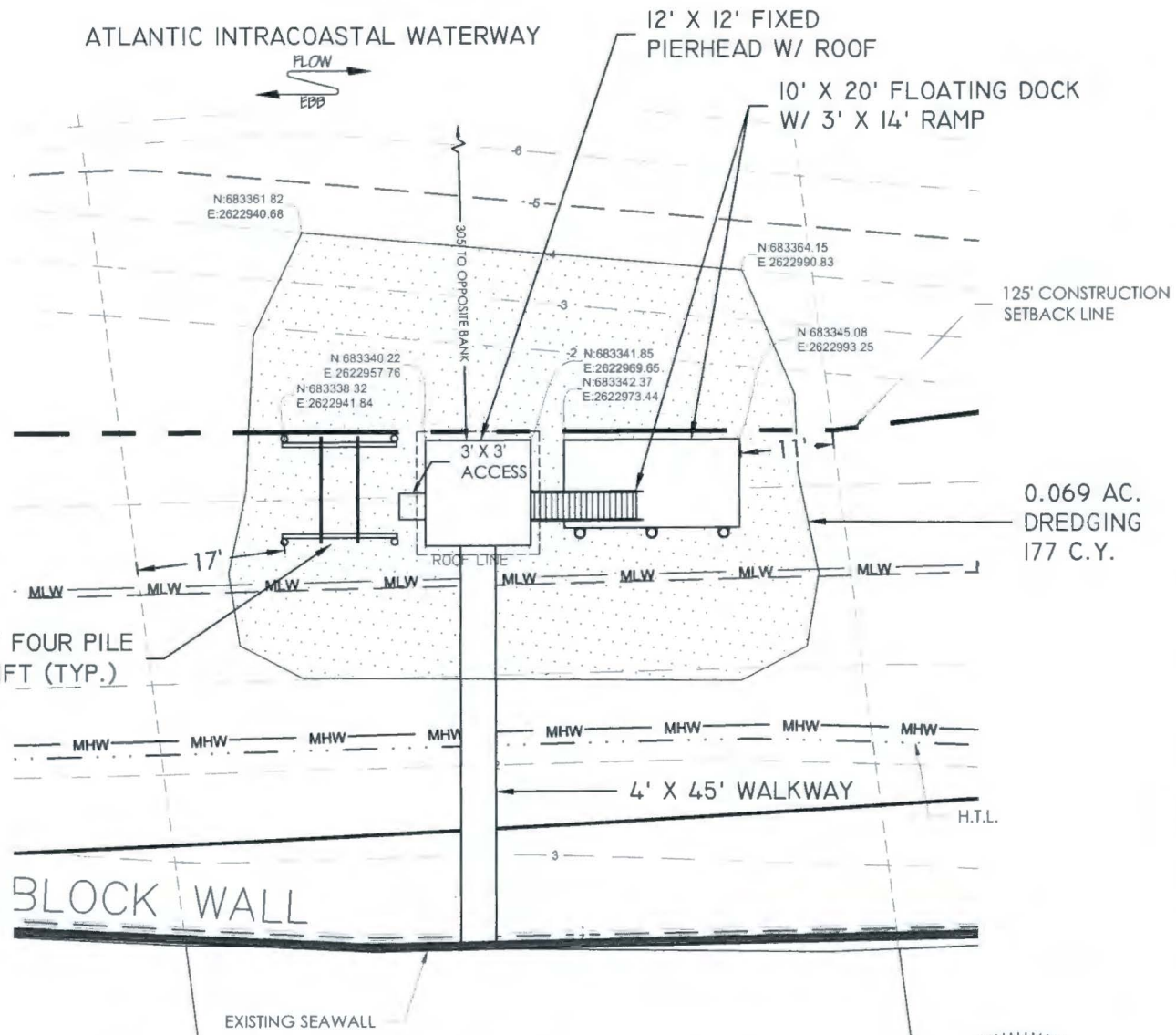

**Lauderdale Bay Docks**  
**SAC 2011-00314**  
**Horry County, South Carolina**  
**Dated: October 20, 2016**  
**Sheet 29 of 34**

**LOT 49**



FOR PERMITTING PURPOSES ONLY - NOT FOR CONSTRUCTION

**EARTHWORKS**  
*planning and design consultants*  
 11655 HIGHWAY 707  
 MURRELLS INLET, SC 29576  
 phone - 843.651.7900  
 fax - 843.651.7903  
 earthworksgroup.com

**DOCK 14 - LOT 49**  
**PROPOSED**  
**LAUDERDALE BAY**  
 DOCK & DREDGE PERMITTING

SCALE  
 1" = 20'

APPLICANT: SALEM WOODS HOLDINGS, LLC  
 3306 GAITHER COURT  
 MYRTLE BEACH, SC 29588

LOCATION: US. HWY 17 BYPASS & LAUDERDALE BLVD.  
 HORRY COUNTY, SOUTH CAROLINA

LAT/LONG: 33.693733, -78.948624  
 USGS QUAD: MYRTLE BEACH

DATE: 12/12/16

TEG PN: 151096

SHEET  
**D14.2**



# DOCK 14

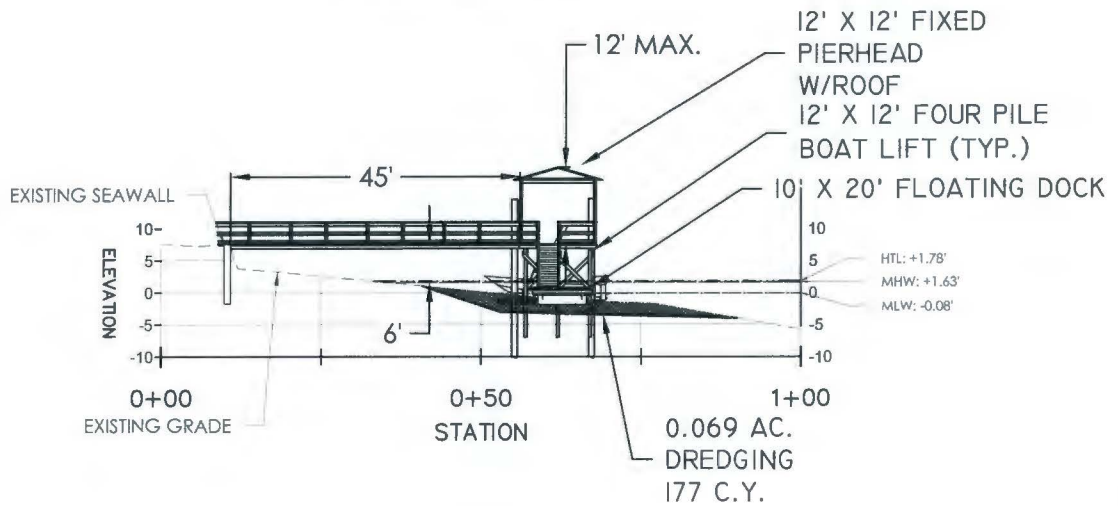

**Lauderdale Bay Docks**  
**SAC 2011-00314**  
**Horry County, South Carolina**  
**Dated: October 20, 2016**  
**Sheet 30 of 34**



ELEVATION DATUM: NAVD88

FOR PERMITTING PURPOSES ONLY - NOT FOR CONSTRUCTION

EARTHWORKS

planning and design consultants

11655 HIGHWAY 707  
 MURRELLS INLET, SC 29576  
 phone - 843.651.7900  
 fax - 843.651.7903  
 earthworksgroup.com

DOCK 14 - LOT 49

PROFILE VIEW

LAUDERDALE BAY

DOCK & DREDGE PERMITTING

SCALE  
1" = 30'

APPLICANT: SALEM WOODS HOLDINGS, LLC  
 3306 GAITHER COURT  
 MYRTLE BEACH, SC 29588

LOCATION: US, HWY 17 BYPASS & LAUDERDALE BLVD.  
 HORRY COUNTY, SOUTH CAROLINA

LAT/LONG: 33.693733, -78.948624  
 USGS QUAD: MYRTLE BEACH

DATE: 12/12/16

SHEET  
D14.3

TEG PN: 151096

ATLANTIC INTRACOASTAL WATERWAY

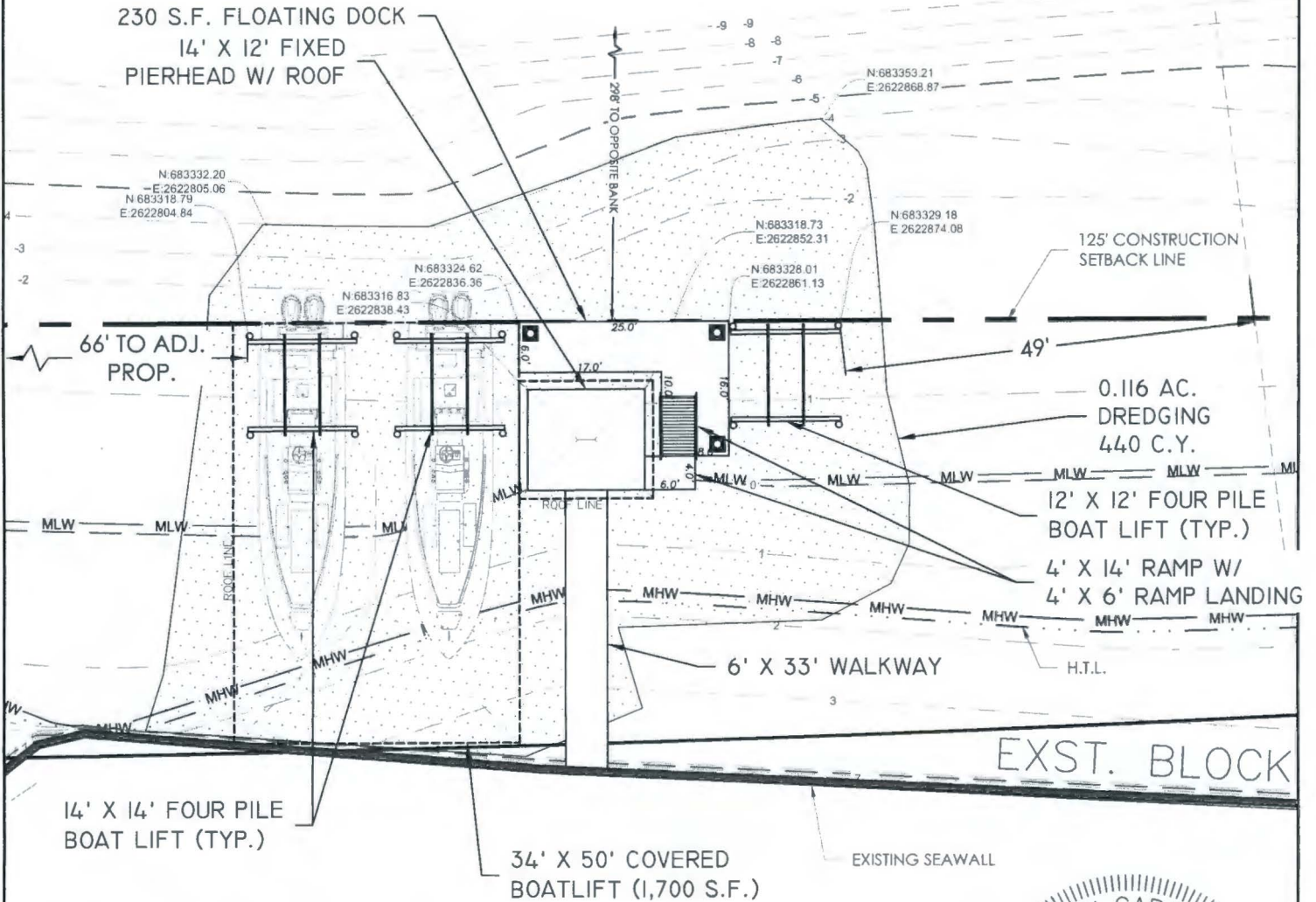
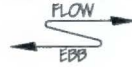

Lauderdale Bay Docks  
 SAC 2011-00314  
 Horry County, South Carolina  
 Dated: October 20, 2016  
 Sheet 31 of 34

LOT 50

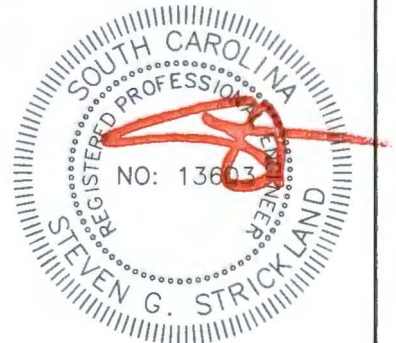

FOR PERMITTING PURPOSES ONLY - NOT FOR CONSTRUCTION

**EARTHWORKS**  
 planning and design consultants  
 11655 HIGHWAY 707  
 MURRELLS INLET, SC 29576  
 phone - 843.651.7900  
 fax - 843.651.7903  
 earthworksgroup.com

**DOCK 15 - LOT 50**  
**PROPOSED**  
 LAUDERDALE BAY  
 DOCK & DREDGE PERMITTING

SCALE  
 1" = 20'

APPLICANT: SALEM WOODS HOLDINGS, LLC  
 3306 GAITHER COURT  
 MYRTLE BEACH, SC 29588

LOCATION: US. HWY 17 BYPASS & LAUDERDALE BLVD.  
 HORRY COUNTY, SOUTH CAROLINA

LAT/LONG: 33.693733, -78.948624  
 USGS QUAD: MYRTLE BEACH

DATE: 12/12/16

TEC PN: 151096

SHEET  
**D15.2**



TWO (2) 14' X 14' BOAT LIFTS  
W/ 34' X 50' COVER (1,700 S.F.)

## DOCK 15

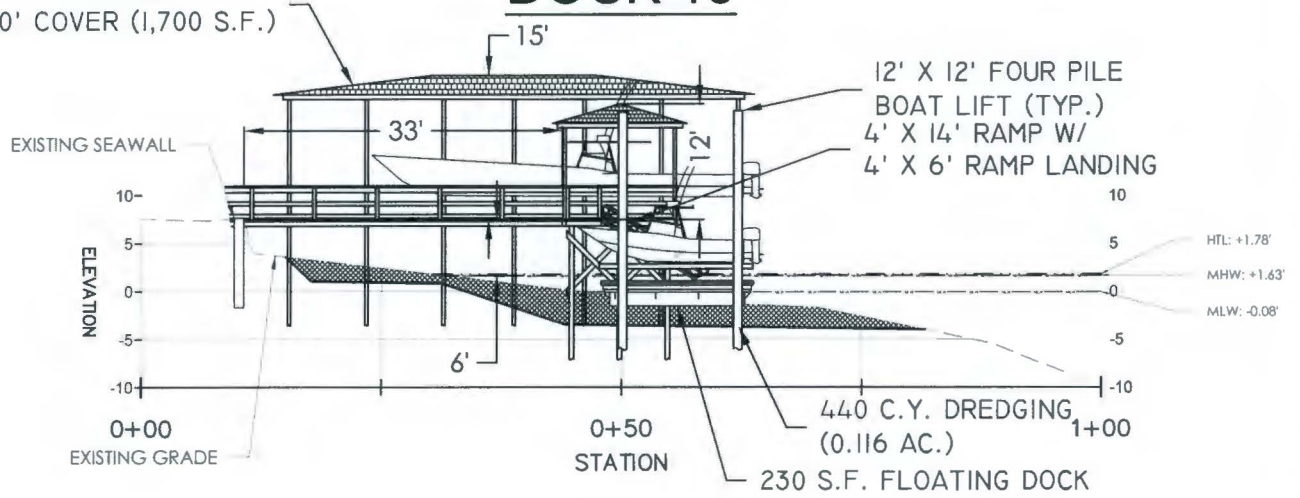

**Lauderdale Bay Docks**  
**SAC 2011-00314**  
**Horry County, South Carolina**  
**Dated: October 20, 2016**  
**Sheet 32 of 34**

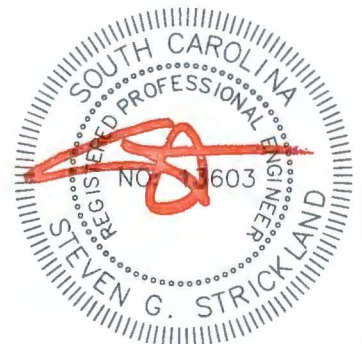

ELEVATION DATUM: NAVD88

FOR PERMITTING PURPOSES ONLY - NOT FOR CONSTRUCTION

**EARTHWORKS**  
*planning and design consultants*  
 11655 HIGHWAY 707  
 MURRELLS INLET, SC 29576  
 phone - 843.651.7900  
 fax - 843.651.7903  
 earthworksgroup.com

**DOCK 14 - LOT 50**  
**PROFILE VIEW**  
 LAUDERDALE BAY  
 DOCK & DREDGE PERMITTING

0 10 20 SCALE 1" = 20'

APPLICANT: SALEM WOODS HOLDINGS, LLC  
 3306 GAITHER COURT  
 MYRTLE BEACH, SC 29588

LOCATION: US. HWY 17 BYPASS & LAUDERDALE BLVD.  
 HORRY COUNTY, SOUTH CAROLINA

LAT/LONG: 33.693733, -78.948624  
 USGS QUAD: MYRTLE BEACH

DATE: 12/12/16

TEG PN: 151096

**SHEET D15.3**



DOCK	LOT(S)	AREA (AC.)	AREA (S.F)	DREDGE (C.Y)
1	OPEN	0.017	741	24
2	25-26	0.030	1307	49
3	27-28	0.021	915	12
4	29-30	0.016	697	2
5	31-32	0.023	1002	9
6	33-34	0.018	784	9
7	35-36	0.032	1394	43
8	37-38	0.045	1960	101
6	39-40	0.058	2526	143
10	41-42	0.057	2483	105
11	43-44	0.049	2134	89
12	45-46	0.036	1568	60
13	47-48	0.038	1655	72
14	49	0.069	3006	177
15	50	0.116	5053	440
TOTALS:		0.625	27225	1334

Lauderdale Bay Docks  
 SAC 2011-00314  
 Horry County, South Carolina  
 Dated: October 20, 2016  
 Sheet 33 of 34



FOR PERMITTING PURPOSES ONLY - NOT FOR CONSTRUCTION

**EARTHWORKS**  
*planning and design consultants*  
 11655 HIGHWAY 707  
 MURRELLS INLET, SC 29576  
 phone - 843.651.7900  
 fax - 843.651.7903  
 earthworksgroup.com

**DREDGING TOTALS**  
 LAUDERDALE BAY  
 DOCK & DREDGE PERMITTING

APPLICANT: SALEM WOODS HOLDINGS, LLC  
 3306 GAITHER COURT  
 MYRTLE BEACH, SC 29588  
 LOCATION: US. HWY 17 BYPASS & LAUDERDALE BLVD.  
 HORRY COUNTY, SOUTH CAROLINA  
 LAT/LONG: 33.693733, -78.948624  
 USGS QUAD: MYRTLE BEACH  
 DATE: 12/12/16  
 SHEET E1.1

**SPOIL BASIN PROFILE**

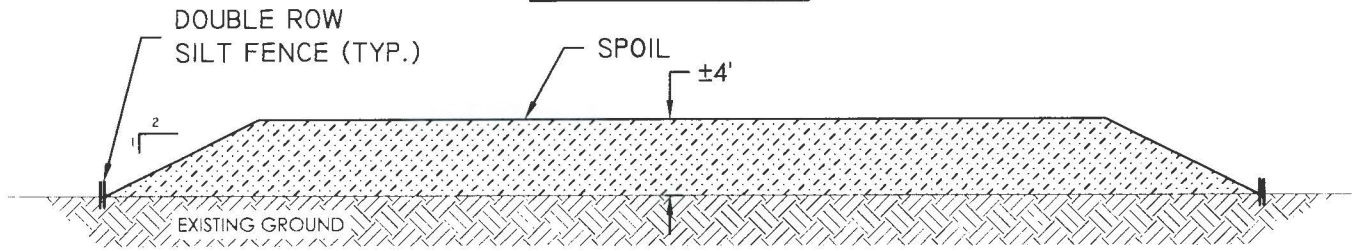

ATLANTIC INTRACOASTAL WATERWAY

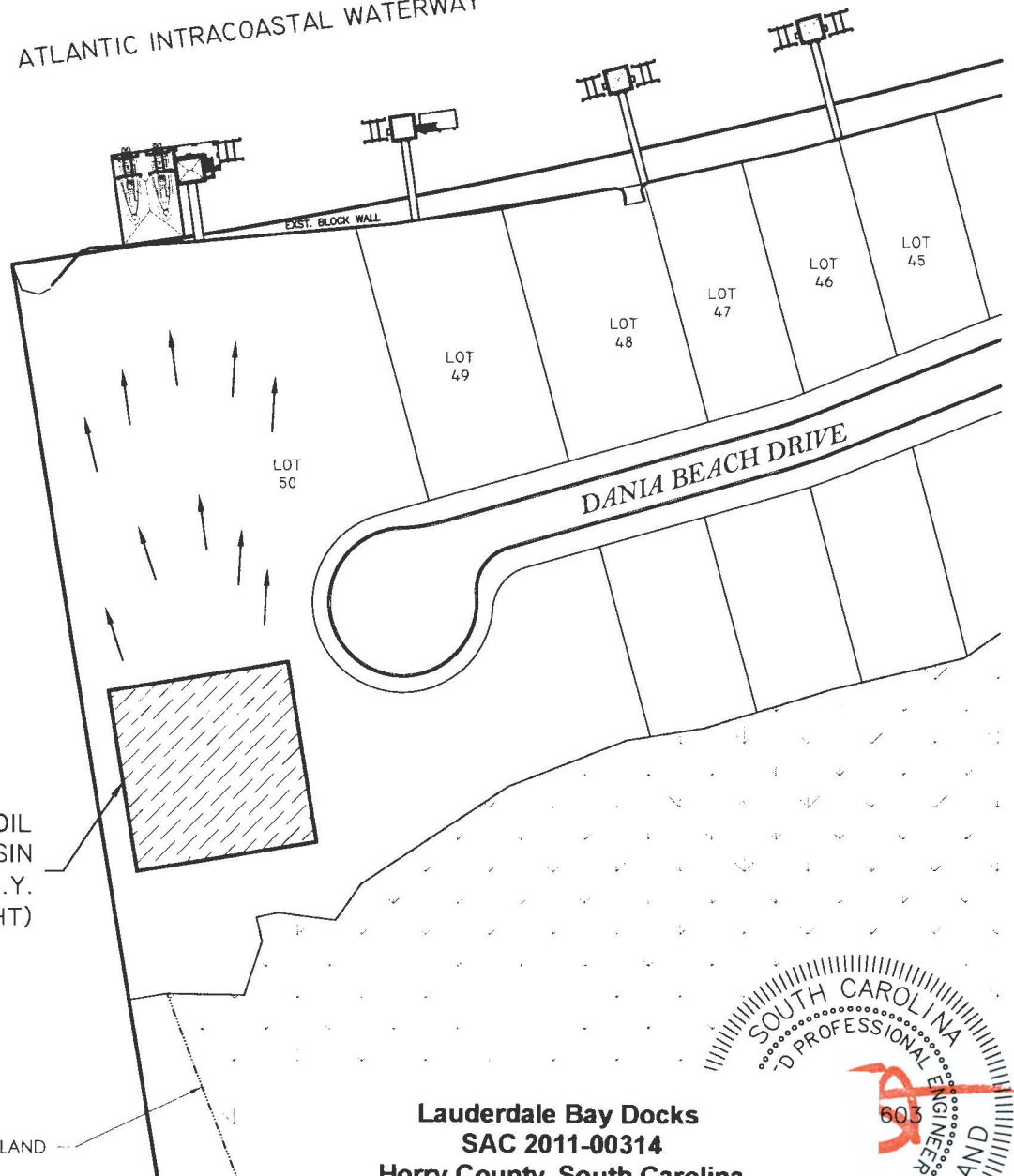

100' X 100' SPOIL DEWATERING BASIN (CAPACITY: 1,573 C.Y. @ 4' HEIGHT)

NOTE:  
SITE WILL BE GRADED TO ENSURE SPOIL BASIN DRAINS TO AIWW AS SHOWN

**Lauderdale Bay Docks  
SAC 2011-00314  
Horry County, South Carolina  
Dated: October 20, 2016  
Sheet 34 of 34**

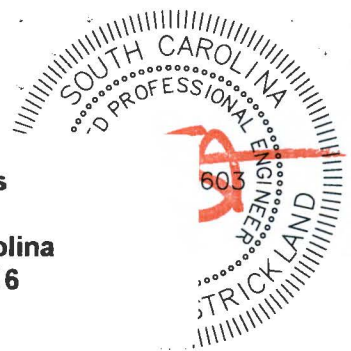

FOR PERMITTING PURPOSES ONLY - NOT FOR CONSTRUCTION

**EARTHWORKS**  
planning and design consultants  
11655 HIGHWAY 707  
MURRELLS INLET, SC 29576  
phone - 843.651.7900  
fax - 843.651.7903  
earthworksgroup.com

**SPOIL DEWATERING PLAN**  
LAUDERDALE BAY  
DOCK & DREDGE PERMITTING  
0 50 100 SCALE 1" = 100'

APPLICANT: SALEM WOODS HOLDINGS, LLC  
3306 GAITHER COURT  
MYRTLE BEACH, SC 29588  
LOCATION: US. HWY 17 BYPASS & LAUDERDALE BLVD.  
HORRY COUNTY, SOUTH CAROLINA  
LAT/LONG: 33.693733, -78.948624  
USGS QUAD: MYRTLE BEACH  
DATE: 12/12/16  
SHEET E1.2  
TEG PN: 151096