

**JOINT**  
**PUBLIC NOTICE**

**CHARLESTON DISTRICT, CORPS OF ENGINEERS**  
**69A Hagood Avenue**  
**Charleston, South Carolina 29403-5107**  
**and**  
**THE S.C. DEPARTMENT OF HEALTH AND ENVIRONMENTAL CONTROL**  
**Office of Ocean and Coastal Resource Management**  
**1362 McMillan Avenue, Suite 400**  
**North Charleston, South Carolina 29405**

REGULATORY DIVISION  
Refer to: SAC-2022-00620

July 17, 2023

Pursuant to Section 10 of the Rivers and Harbors Act of 1899 (33 U.S.C. 403), Sections 401 and 404 of the Clean Water Act (33 U.S.C. 1344), Section 14 of the Rivers and Harbors Act of 1899, 33 USC 408 (Section 408) and the South Carolina Coastal Zone Management Act (48-39-10 et.seq.), an application has been submitted to the Department of the Army and the S.C. Department of Health and Environmental Control by

**Mr. Michael Lesinski**  
**Technical Director**  
**United States Coast Guard**  
**Civil Engineering Unit Miami**  
**15608 SW 117th Avenue**  
**Miami, Florida 33177**

for a permit to perform maintenance dredging in the

**COOPER RIVER**

located at Pier Papa near the intersection of Halsey Street and S. Hobson Avenue on the Federal Complex, North Charleston, Charleston County, South Carolina (Latitude: 32.8520°, Longitude: -79.9453°), Charleston Quadrangle.

In order to give all interested parties an opportunity to express their views

**NOTICE**

is hereby given that written statements regarding the proposed work will be received by the **Corps** until

**15 Days from the Date of this Notice,**

and **SCDHEC** will receive written statements regarding the proposed work until

### **30 Days from the Date of this Notice**

from those interested in the activity and whose interests may be affected by the proposed work.

**NOTE: This public notice and associated plans are available on the Corps' website at: <http://www.sac.usace.army.mil/Missions/Regulatory/PublicNotices> .**

#### **Applicant's Stated Purpose**

According to the applicant, the purpose of the proposed project is maintenance dredging an existing berthing area for improved navigational access.

#### **Project Description**

The proposed work consists of maintenance dredging by cutter-head dredge. In detail, this project will involve dredging the existing Pier Papa berthing and its surrounding area to a depth of -32' with -2' of over-depth to maintain navigation at Pier Papa. The initial dredge cycle is anticipated to total 350,000 cubic yards and year-two through year-ten dredges are estimated to produce 200,000 cubic yards of material per year at the current sediment deposition rates. The material will be disposed of in an approved upland disposal site over a 10-year period for a total of 2,150,000 cubic yards.

#### **Avoidance and Minimization**

The applicant has stated that the proposed project will avoid and/or minimize impacts to the aquatic environment by designing the project to 'remove the least amount of material to restore the navigable depth of the waterway'.

#### **Proposed Compensatory Mitigation**

The applicant has proposed not to mitigate for impacts to wetlands and/or waters of the United States.

#### **South Carolina Department of Health and Environmental Control**

The District Engineer has concluded that the discharges associated with this project, both direct and indirect, should be reviewed by the certifying authority, South Carolina Department of Health and Environmental Control, in accordance with provisions of Section 401 of the Clean Water Act (CWA). The CWA Section 401 Certification Rule (Certification Rule, 40 CFR 121), effective September 11, 2020, requires certification, or waiver, for any license or permit that authorizes an activity that may result in a discharge. The scope of a CWA Section 401 Certification is limited to assuring that a discharge from a Federally licensed or permitted activity will comply with water quality requirements. The

applicant is responsible for requesting certification and providing required information to the certifying authority. In accordance with Certification Rule part 121.12, the Corps will notify the U.S. Environmental Protection Agency Administrator when it has received a Department of the Army (DA) permit application and the related certification. The Administrator is responsible for determining if the discharge may affect water quality in a neighboring jurisdiction. The DA permit may not be issued pending the conclusion of the Administrator's determination of effects on neighboring jurisdictions.

The work shown on this application must also be certified as consistent with applicable provisions of the Coastal Zone Management Program (15 CFR 930). This activity may also require evaluation for compliance with the S. C. Construction in Navigable Waters Permit Program. State review, permitting and certification is conducted by the S. C. Department of Health and Environmental Control. The District Engineer will not process this application to a conclusion until such certifications are received. The applicant is hereby advised that supplemental information may be required by the State to facilitate the review.

### **Essential Fish Habitat**

This notice initiates the Essential Fish Habitat (EFH) consultation requirements of the Magnuson-Stevens Fishery Conservation and Management Act. Implementation of the proposed project would impact 21.5 acres of estuarine substrates and emergent wetlands utilized by various life stages of species comprising the shrimp, and snapper-grouper management complexes. The District Engineer's initial determination is that the proposed action would not have a substantial individual or cumulative adverse impact on EFH or fisheries managed by the South Atlantic Fishery Management Council and the National Marine Fisheries Service (NMFS). The District Engineer's final determination relative to project impacts and the need for mitigation measures is subject to review by and coordination with the NMFS.

### **Endangered Species**

Pursuant to the Section 7 of the Endangered Species Act of 1973 (as amended), the Corps has reviewed the project and based on the location of the project and available information, the following species may be present in the County(s) where the work will occur:

*Frosted flatwoods salamander (Ambystoma cingulatum)*

*American wood stork (Mycteria americana)*

*Eastern black rail (Laterallus jamaicensis jamaicensis)*

*Piping plover (Charadrius melodus)*

*Red-cockaded woodpecker (Picoides borealis)*

*Rufa red knot (Calidris canutus rufa)*

*Atlantic sturgeon (Acipenser oxyrinchus)*

*Shortnose sturgeon (Acipenser brevirostrum)*

*Finback whale (Balaenoptera physalus)*

*Humpback whale (Megaptera novaeangliae)*  
*Northern long-eared bat (Myotis septentrionalis)*  
*Right whale (Eubalaena glacialis)*  
*Sei whale (Balaenoptera borealis)*  
*Sperm whale (Physeter macrocephalus)*  
*West Indian manatee (Trichechus manatus)*  
*American chaffseed (Schwalbea americana)*  
*Canby's dropwort (Oxypolis canbyi)*  
*Pondberry (Lindera melissifolia)*  
*Seabeach amaranth (Amaranthus pumilus)*  
*Green sea turtle (Chelonia mydas)*  
*Kemp's Ridley sea turtle (Lepidochelys kempii)*  
*Leatherback sea turtle (Dermochelys coriacea)*  
*Loggerhead sea turtle (Caretta caretta)*

Based on all information provided by the applicant and the most recently available information, the District Engineer has determined the following:

The project will have no effect on Frosted flatwoods salamander (*Ambystoma cingulatum*), American wood stork (*Mycteria americana*), Eastern black rail (*Laterallus jamaicensis jamaicensis*), Piping plover (*Charadrius melodus*), Red-cockaded woodpecker (*Picoides borealis*), Rufa red knot (*Calidris canutus rufa*), Finback whale (*Balaenoptera physalus*), Humpback whale (*Megaptera novaeangliae*), Northern long-eared bat (*Myotis septentrionalis*), Right whale (*Eubalaena glacialis*), Sei whale (*Balaenoptera borealis*), Sperm whale (*Physeter macrocephalus*), American chaffseed (*Schwalbea americana*), Canby's dropwort (*Oxypolis canbyi*), Pondberry (*Lindera melissifolia*), Seabeach amaranth (*Amaranthus pumilus*), Green sea turtle (*Chelonia mydas*), Kemp's Ridley sea turtle (*Lepidochelys kempii*), Leatherback sea turtle (*Dermochelys coriacea*), Loggerhead sea turtle (*Caretta caretta*) and will not result in the destruction or adverse modification of designated or proposed critical habitat.

The project is not likely to adversely affect Atlantic sturgeon (*Acipenser oxyrinchus*), Shortnose sturgeon (*Acipenser brevirostrum*) and West Indian manatee (*Trichechus manatus*) or result in the destruction or adverse modification of designated or proposed critical habitat. This public notice serves as a request for written concurrence from the U.S. Fish and Wildlife Service and/or the National Marine Fisheries Service on this determination.

This public notice serves as a request to the U.S. Fish and Wildlife Service and the National Marine Fisheries Service for any additional information they may have on whether any listed or proposed endangered or threatened species or designated or proposed critical habitat may be present in the area which would be affected by the activity.

## **Cultural Resources**

Pursuant to Section 106 of the National Historic Preservation Act (NHPA), this public notice also constitutes a request to Indian Tribes to notify the District Engineer of any historic properties of religious and cultural significance to them that may be affected by the proposed undertaking.

In accordance with Section 106 of the NHPA, the District Engineer has consulted South Carolina ArchSite (GIS), for the presence or absence of historic properties (as defined in 36 C.F.R. 800.16)(1)(1)), and has initially determined that no historic properties are present; therefore, there will be no effect on historic properties. To ensure that other historic properties that the District Engineer is not aware of are not overlooked, this public notice also serves as a request to the State Historic Preservation Office and any other interested parties to provide any information they may have with regard to historic properties. This public notice serves as a request for concurrence within 30 days from the SHPO (and/or Tribal Historic Preservation Officer).

The District Engineer's final eligibility and effect determination will be based upon coordination with the SHPO and/or THPO, as appropriate and required and with full consideration given to the proposed undertaking's potential direct and indirect effects on historic properties within the Corps-identified permit area.

## **Corps' Evaluation**

The decision whether to issue a permit will be based on an evaluation of the probable impact including cumulative impacts of the proposed activity on the public interest and will include application of the guidelines promulgated by the Administrator, Environmental Protection Agency (EPA), under authority of Section 404(b) of the Clean Water Act and, as appropriate, the criteria established under authority of Section 102 of the Marine Protection, Research and Sanctuaries Act of 1972, as amended. That decision will reflect the national concern for both protection and utilization of important resources. The benefit which reasonably may be expected to accrue from the project must be balanced against its reasonably foreseeable detriments. All factors which may be relevant to the project will be considered including the cumulative effects thereof; among those are conservation, economics, aesthetics, general environmental concerns, wetlands, historic properties, fish and wildlife values, flood hazards, flood plain values, land use, navigation, shoreline erosion and accretion, recreation, water supply and conservation, water quality, energy needs, safety, food and fiber production and, in general, the needs and welfare of the people. A permit will be granted unless the District Engineer determines that it would be contrary to the public interest. In cases of conflicting property rights, the Corps cannot undertake to adjudicate rival claims.

## **Solicitation of Public Comment**

The Corps is soliciting comments from the public; Federal, state, and local agencies and officials; Indian Tribes; and other interested parties in order to consider and evaluate

the impacts of this activity. Any comments received will be considered by the Corps to determine whether to issue, modify, condition or deny a permit for this project. To make this decision, comments are used to assess impacts on endangered species, historic properties, water quality, general environmental effects, and the other public interest factors listed above. Comments are used in the preparation of an Environmental Assessment and/or an Environmental Impact Statement pursuant to the National Environmental Policy Act. Comments are also used to determine the need for a public hearing and to determine the overall public interest of the activity. Any person may request, in writing, within the comment period specified in this notice, that a public hearing be held to consider this application. Requests for a public hearing shall state, with particularity, the reasons for holding a public hearing.

**Please submit comments in writing, identifying the project of interest by public notice/file number (SAC-2022-00620), to [Shawn.A.Boone@usace.army.mil](mailto:Shawn.A.Boone@usace.army.mil) or the following address:**

**U.S. Army Corps of Engineers  
ATTN: REGULATORY DIVISION  
69A Hagood Avenue  
Charleston, South Carolina 29403-5107**

If there are any questions concerning this public notice, please contact Shawn Boone, Project Manager, at (843) 329-8158, toll free at 1-866-329-8187, or by email at [Shawn.A.Boone@usace.army.mil](mailto:Shawn.A.Boone@usace.army.mil).

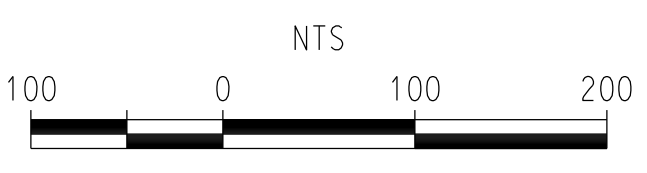
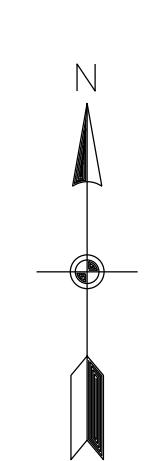

CLOUTER CREEK REACH

DREDGING LIMIT (32' MLLW)  
THEORETICAL TOP OF SLOPE (0' MLLW)

DREDGING LIMIT (32' MLLW)  
THEORETICAL TOP OF SLOPE (0' MLLW)

### USCG PIER PAPA

REDGED DEPTH: 32' PLUS 2' ALLOWABLE OVERDEPTH  
4:1 SIDE SLOPES  
ESTIMATED QUANTITY: 250,000 to 350,000 CY  
PLACEMENT: UPLAND AT CLOUTER CREEK AND/OR DANIEL ISLAND  
**21.5 Acres**

**NOTES:**

1. THE INFORMATION DEPICTED ON THIS DRAWING IS FOR PERMITTING PURPOSES.
2. DEPTHS ARE IN FEET AND TENTHS AND REFER TO MEAN LOWER LOW WATER (MLLW).
3. HORIZONTAL DATUM IS SOUTH CAROLINA STATE PLANE COORDINATES NAD 1983.

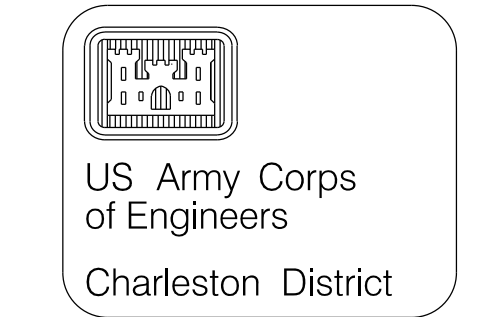

DATE	DESCRIPTION

Date:	26 JAN 2023	Rev:	
Design No.:		Design No.:	
Drawn By:	JJK	Checked By:	MJCG
Released By:	JRU	Drawn Code:	
Designed By:	JJK	Scale:	AS SHOWN

U.S. ARMY ENGINEER DISTRICT	
CORPS OF ENGINEERS	
CHARLESTON, SOUTH CAROLINA	
SAC #:	

UNITED STATES COAST GUARD	
MAINTENANCE DREDGING	
<b>PERMIT PLANS</b>	
USCG PIER PAPA	
BERKELEY COUNTY, SOUTH CAROLINA	

SHEET REFERENCE NUMBER	
<b>01</b>	
SHEET 1 OF 7	

PERMIT

NO.	DATE	DESCRIPTION	MARK

Designer by:	JJK	Date:	25 JAN 2023	Rev:	
Drawn by:	JJK	Design No.:	PERMIT PLANS		
Released by:	JRU	Drawn Code:			

US ARMY ENGINEER DISTRICT CORPS OF ENGINEERS CHARLESTON, SOUTH CAROLINA	SAC #:
---	--------

UNITED STATES COAST GUARD MAINTENANCE DREDGING	PERMIT PLANS	USCG PIER PAPA
BERKELEY COUNTY, SOUTH CAROLINA		

SHEET REFERENCE NUMBER
C-02
SHEET 2 OF 7

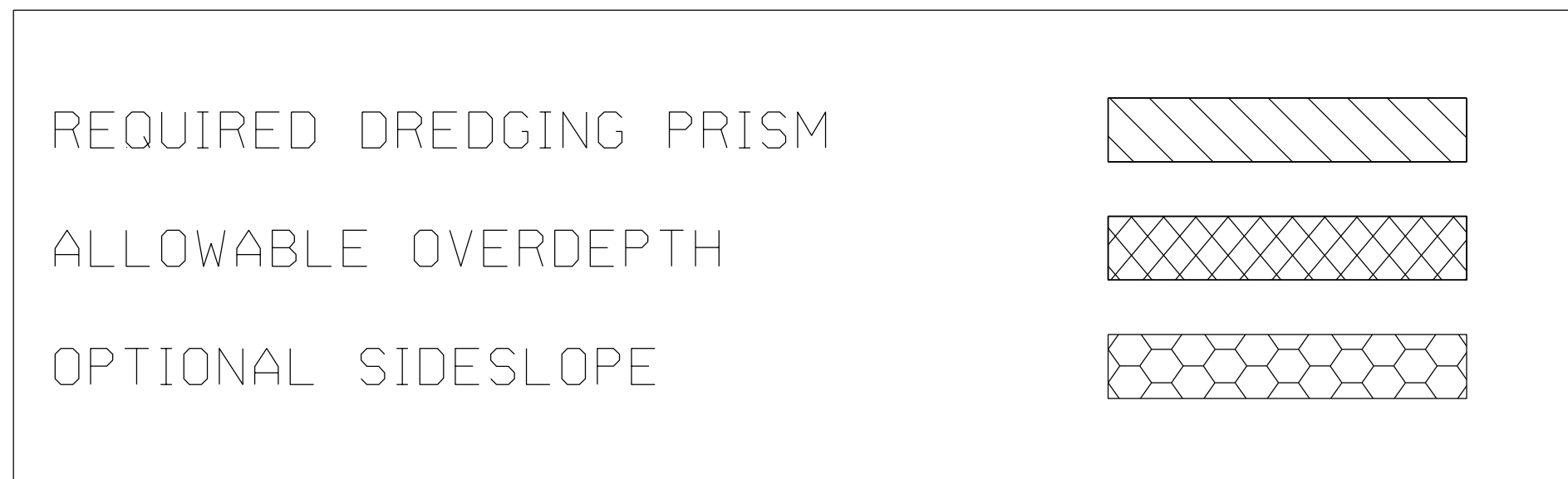
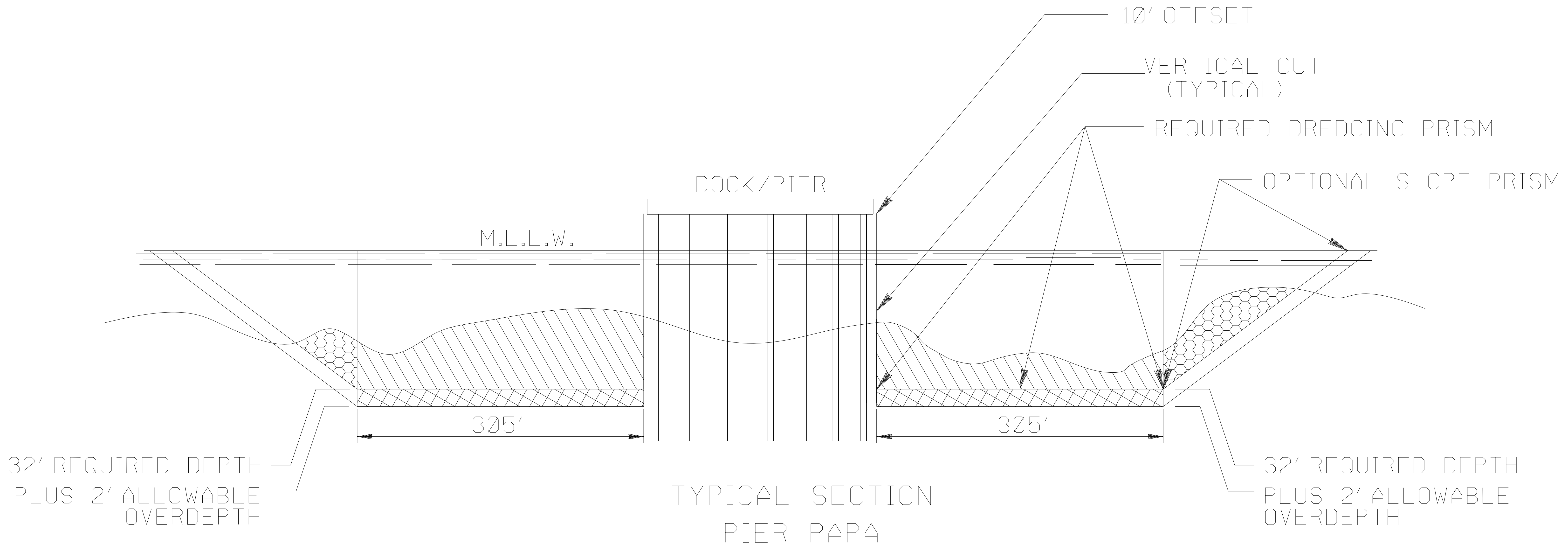

NOTES:

1. ALL HORIZONTAL COORDINATES ARE BASED ON THE SOUTH CAROLINA STATE PLANE COORDINATE SYSTEM, NAD83 (NSRS2007).
2. VERTICAL CUT AT DOCK FACE AND MOORING DOLPHINS IS LIMITED TO 10 FEET FROM STRUCTURE.



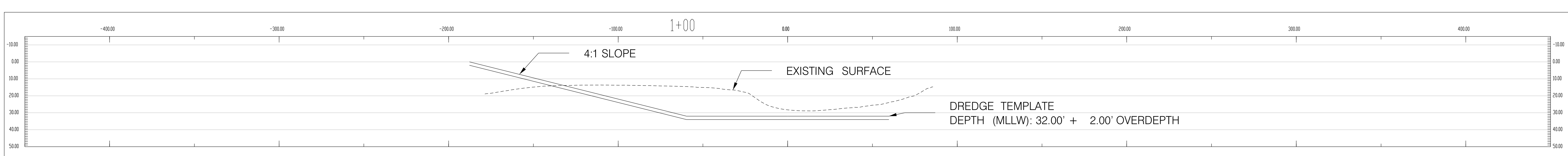
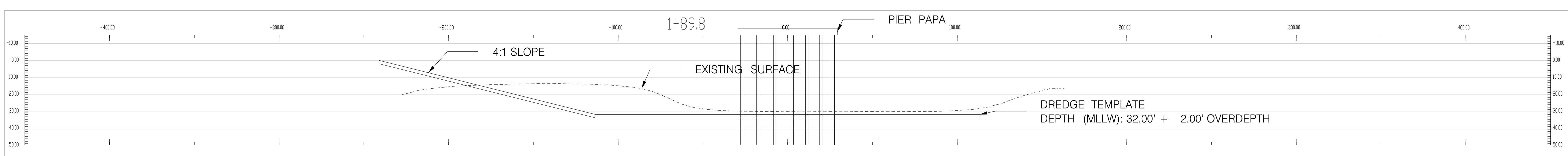
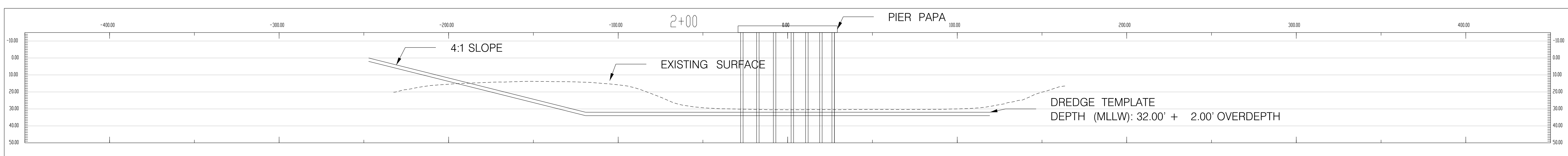
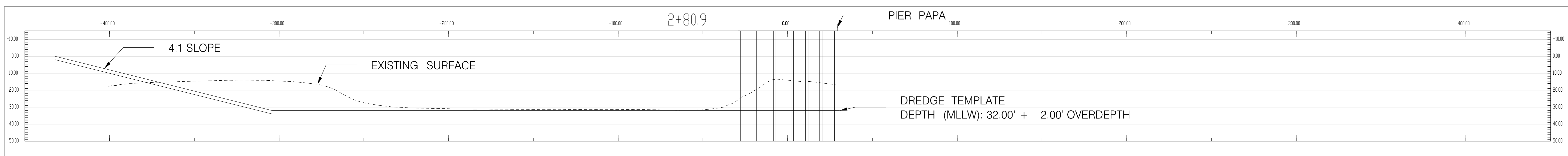
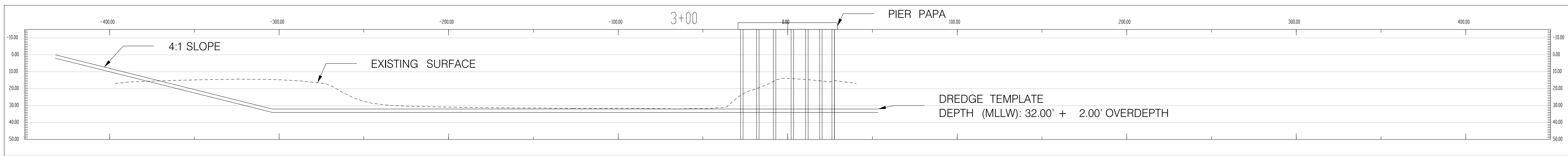

SCALE OF FEET  
1" = 100'

DATE	DESCRIPTION	DATE	DESCRIPTION

Designed by: JJK	Date: 01 FEB 2023	Permit No.:	PERMIT PLANS
Drawn by: JJK	Check by: MJCG	Design No.:	
Reviewed by: JJK	Reviewed by: JJK	Drawn Code:	
Submitted by: JERMEY R. JOHNSON, P.E.	File name: r19m1012-0000-0000.dwg	Plot date: 01 FEB 2023	
	Plot scale: 1" = 100'		

UNITED STATES COAST GUARD  
MAINTENANCE DREDGING  
**PERMIT PLANS**  
USCG PIER PAPA  
BERKELEY COUNTY, SOUTH CAROLINA

SHEET  
REFERENCE  
NUMBER  
**C-03**  
SHEET 3 OF 7

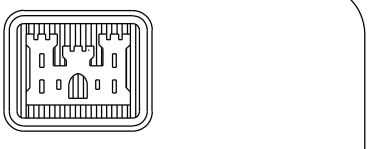

US Army Corps  
of Engineers  
Charleston District

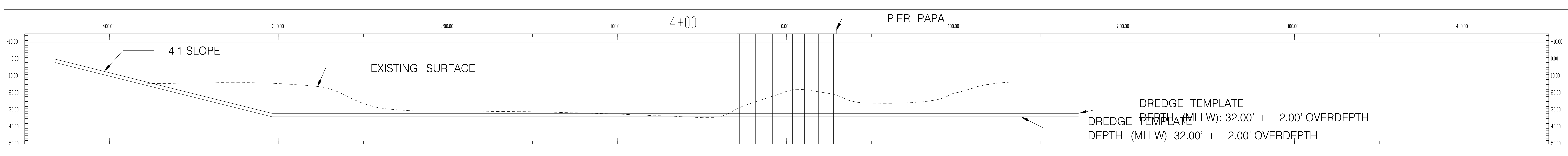
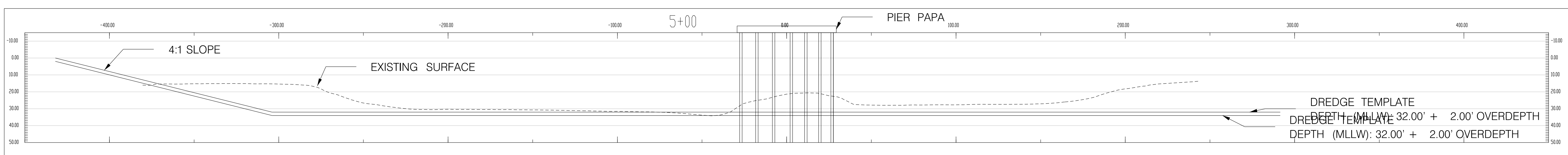
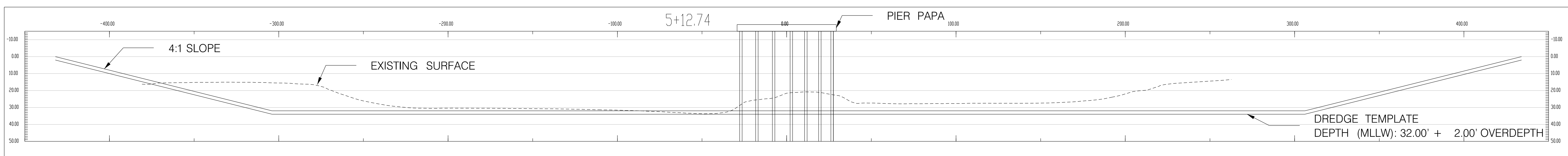
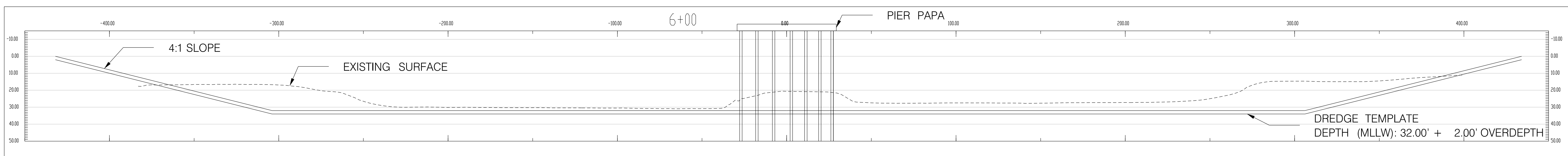
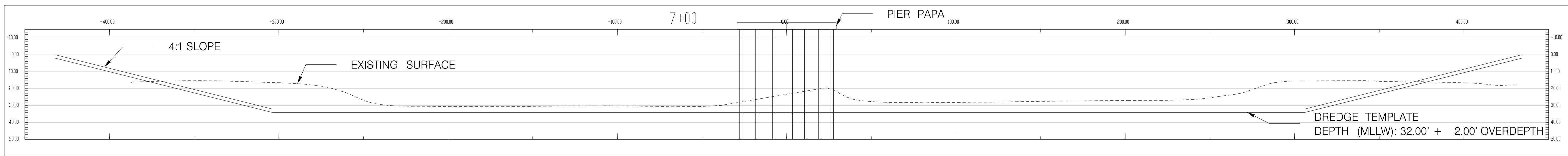

SCALE OF FEET  
1" = 100'

DATE	DESCRIPTION	DATE	DESCRIPTION

Designed by: JJK	Check by: MJJG	Date: 01 FEB 2023	Permit No.:
Drawn by: JJK	Reviewed by: JRJ	Design No.:	PERMIT PLANS
Submitted by: JERMEY R. JOHNSON, P.E.			Drawing Code:
SAC #:			File name: rjw110114-000001.dwg No date: 01 FEB 2023 Proj name: USCG

UNITED STATES COAST GUARD  
MAINTENANCE DREDGING  
**PERMIT PLANS**  
USCG PIER PAPA  
BERKELEY COUNTY, SOUTH CAROLINA

SHEET REFERENCE NUMBER  
**C-04**  
SHEET 4 OF 7

NO.	DATE	DESCRIPTION

Designated by: <b>JUK</b>	Date: <b>01 FEB 2023</b>	Rec. #: 01 FEB 2023
Drawn by: <b>JUK</b>	Checked by: <b>MJCG</b>	Design No. / <b>PERMIT PLANS</b>
Reviewed by: <b>JRJ</b>	Drawing Code: 01 FEB 2023	File name: <small>river-maint-permit-plans-02.dwg</small> Plot date: 01 FEB 2023 Job name: <b>USCG PIER PAPA</b>
Submitted by: <b>JERMEY R. JOHNSON, P.E.</b>		SAC #: #

UNITED STATES COAST GUARD  
MAINTENANCE DREDGING  
**PERMIT PLANS**  
USCG PIER PAPA  
BERKELEY COUNTY, SOUTH CAROLINA

SHEET  
REFERENCE  
NUMBER  
**C-05**  
SHEET 5 OF 7

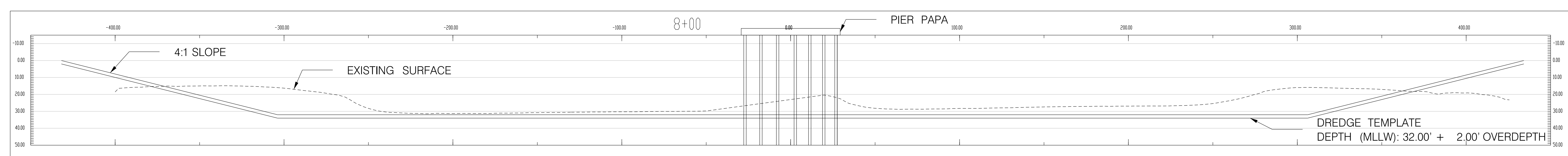
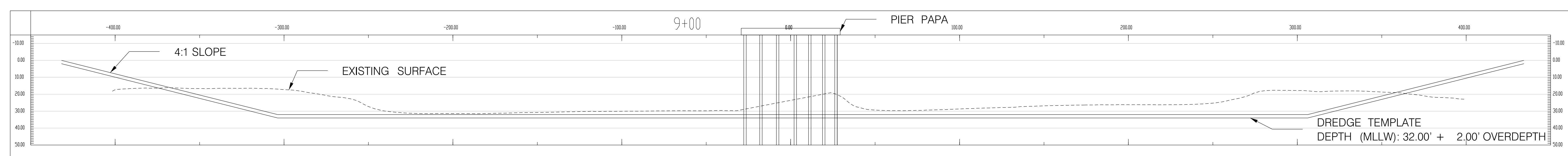
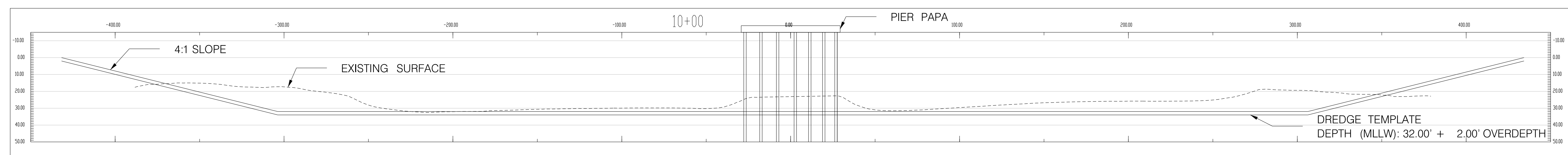
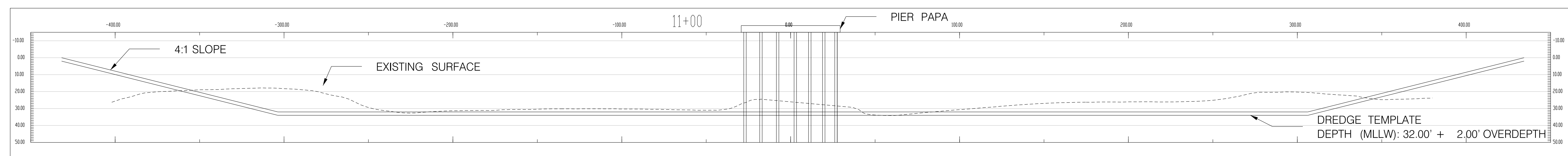
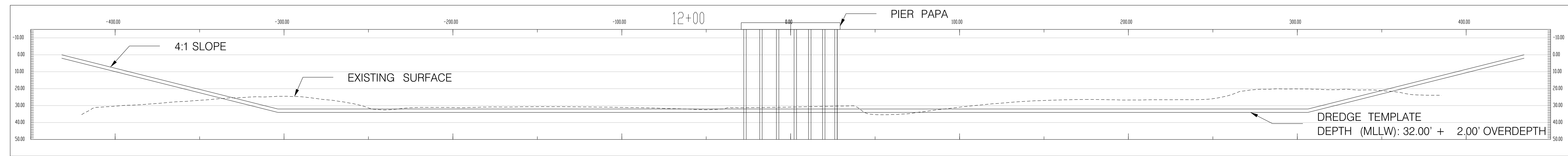

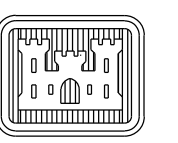

US Army Corps  
of Engineers  
Charleston District

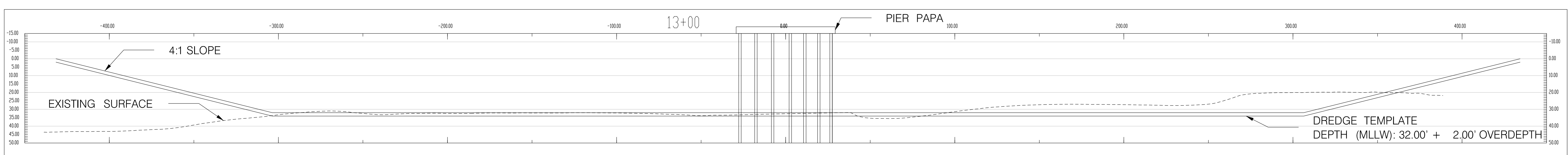
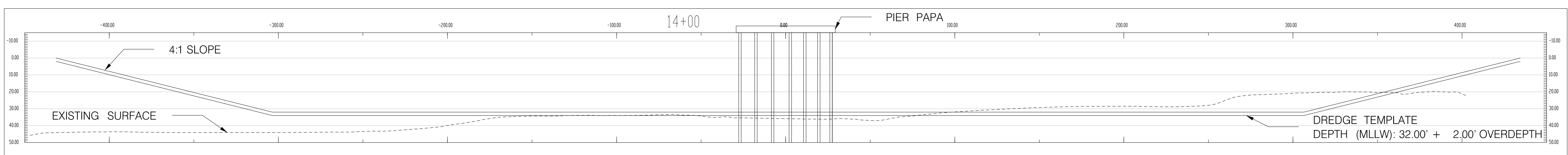
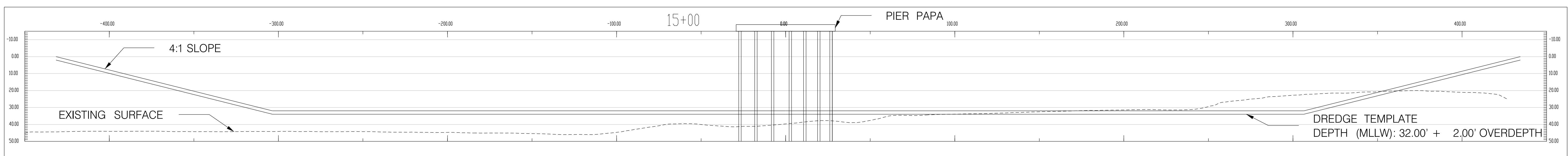
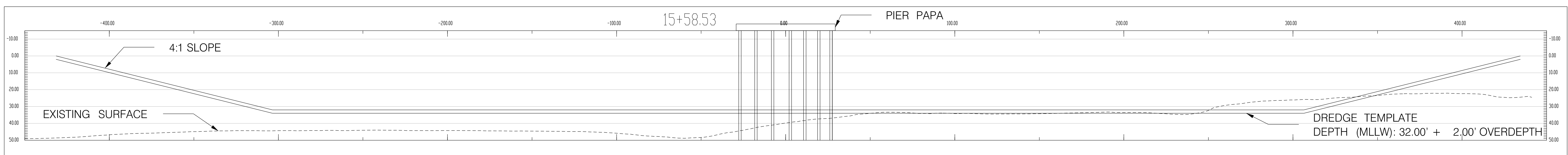
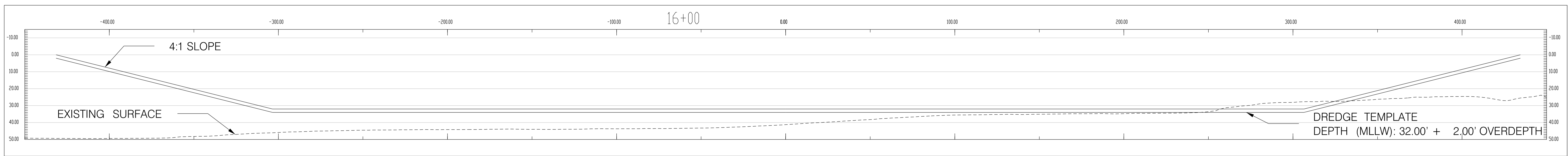

DATE	DESCRIPTION

DESIGNED BY: JUK	DATE: 01 FEB 2023	SCALE: 1"=100'
DRAWN BY: JUK	DESIGN NO.: PERMIT PLANS	FILE NAME: 171501-01-01-01-01-01.dwg
CHECKED BY: MJC	DRAWING CODE: MJC	DATE: 01 FEB 2023
REVIEWED BY: JRU	PROJECT NO.: 171501-01-01-01-01	DWG CODE: MJC
SUBMITTED BY: JEREMY R. JOHNSON, P.E.	PROJECT NAME: PIER PAPA	DWG DATE: 01 FEB 2023

UNITED STATES COAST GUARD  
MAINTENANCE DREDGING  
**PERMIT PLANS**  
USCG PIER PAPA  
BERKELEY COUNTY, SOUTH CAROLINA

SHEET  
REFERENCE  
NUMBER  
**C-06**

SHEET 6 OF 7

PERMIT

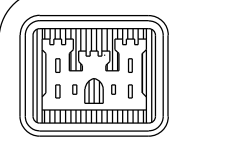

US Army Corps  
of Engineers  
Charleston District

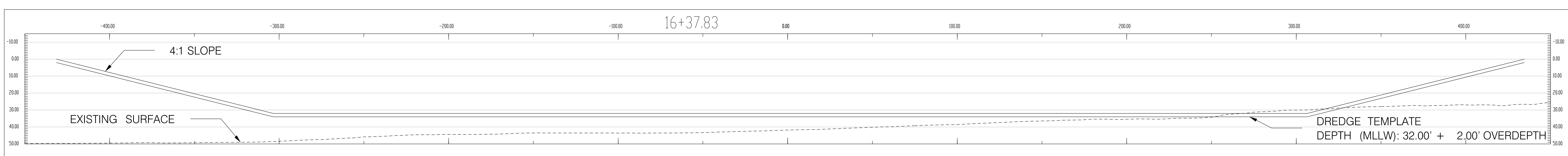
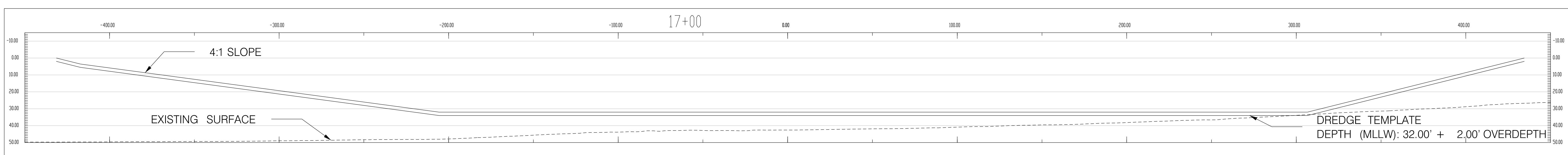
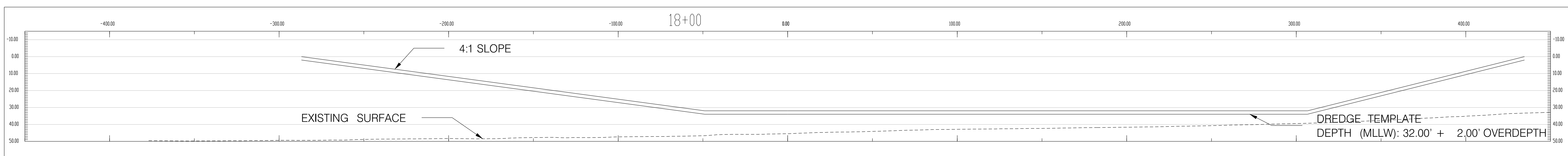
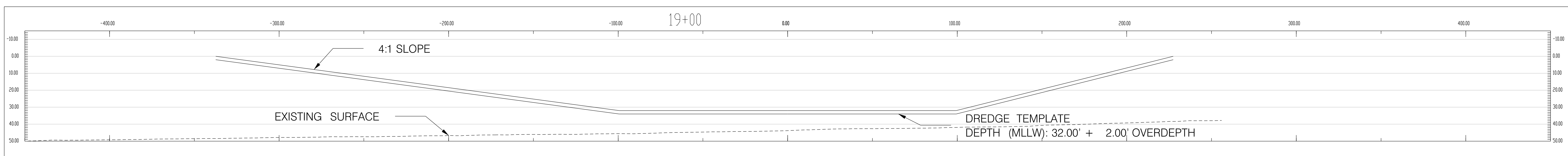
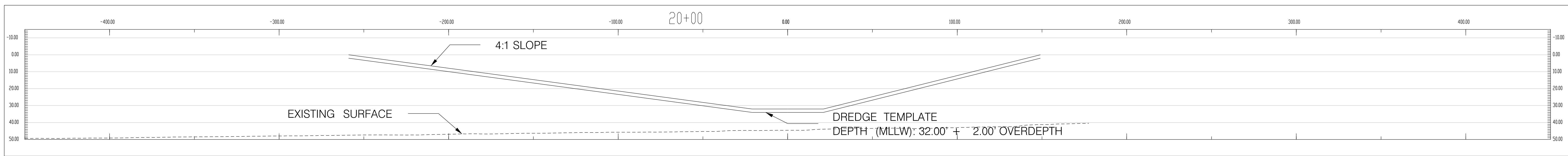

DATE	DESCRIPTION	MARK	DATE	DESCRIPTION	MARK

Designed by:	JJK	Check by:	MJCG	Date:	01 FEB 2023
Drawn by:	JJK	Reviewed by:	JRJ	Design No.:	PERMIT PLANS
Submitted by:	JERMEY R. JOHNSON, P.E.	Drawn Code:		File Name:	170101-001-0000-001.dwg
				Plot Date:	01 FEB 2023

UNITED STATES COAST GUARD  
MAINTENANCE DREDGING  
**PERMIT PLANS**  
USCG PIER PAPA  
BERKELEY COUNTY, SOUTH CAROLINA

SHEET  
REFERENCE  
NUMBER  
**C-07**  
SHEET 7 OF 7

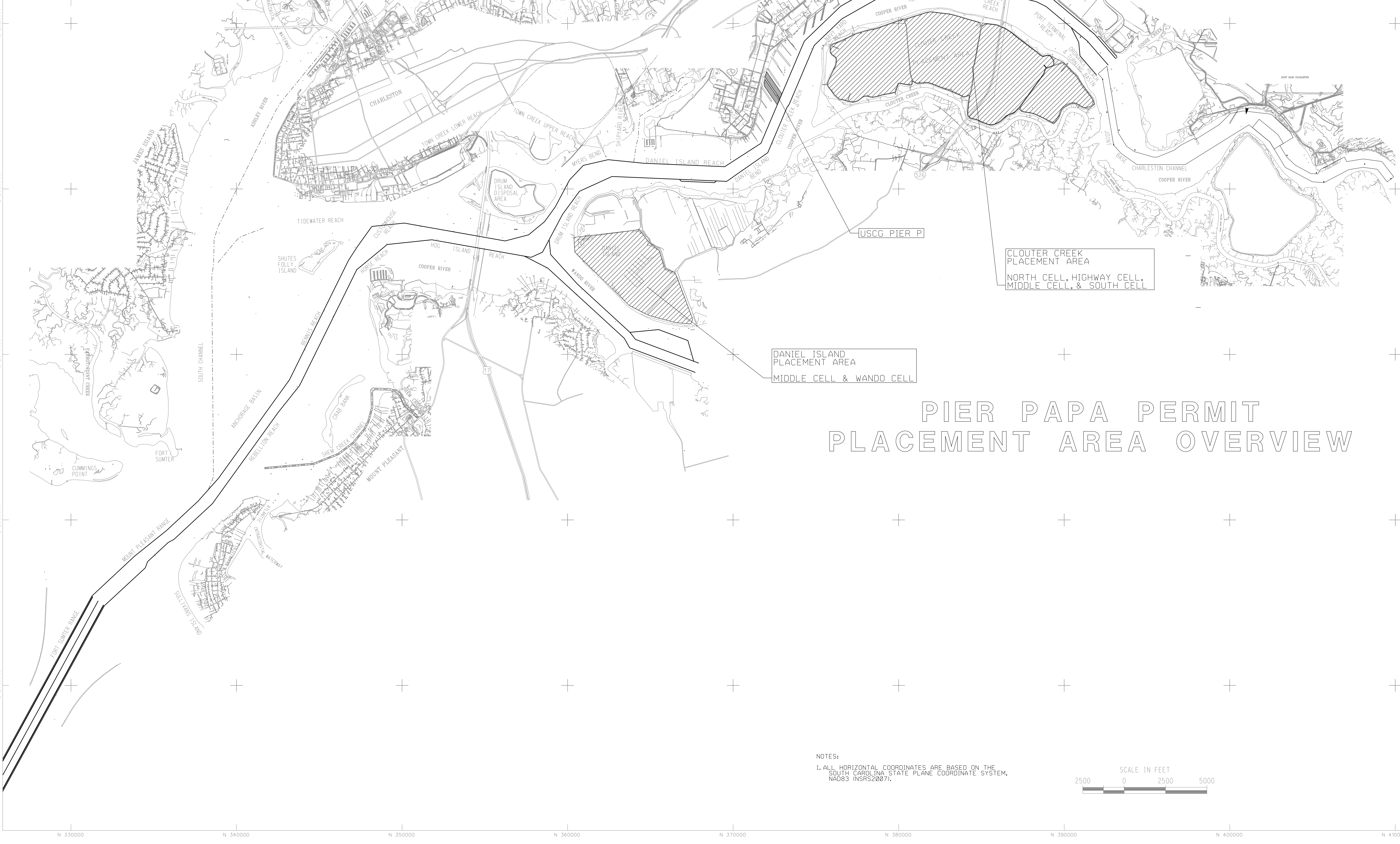
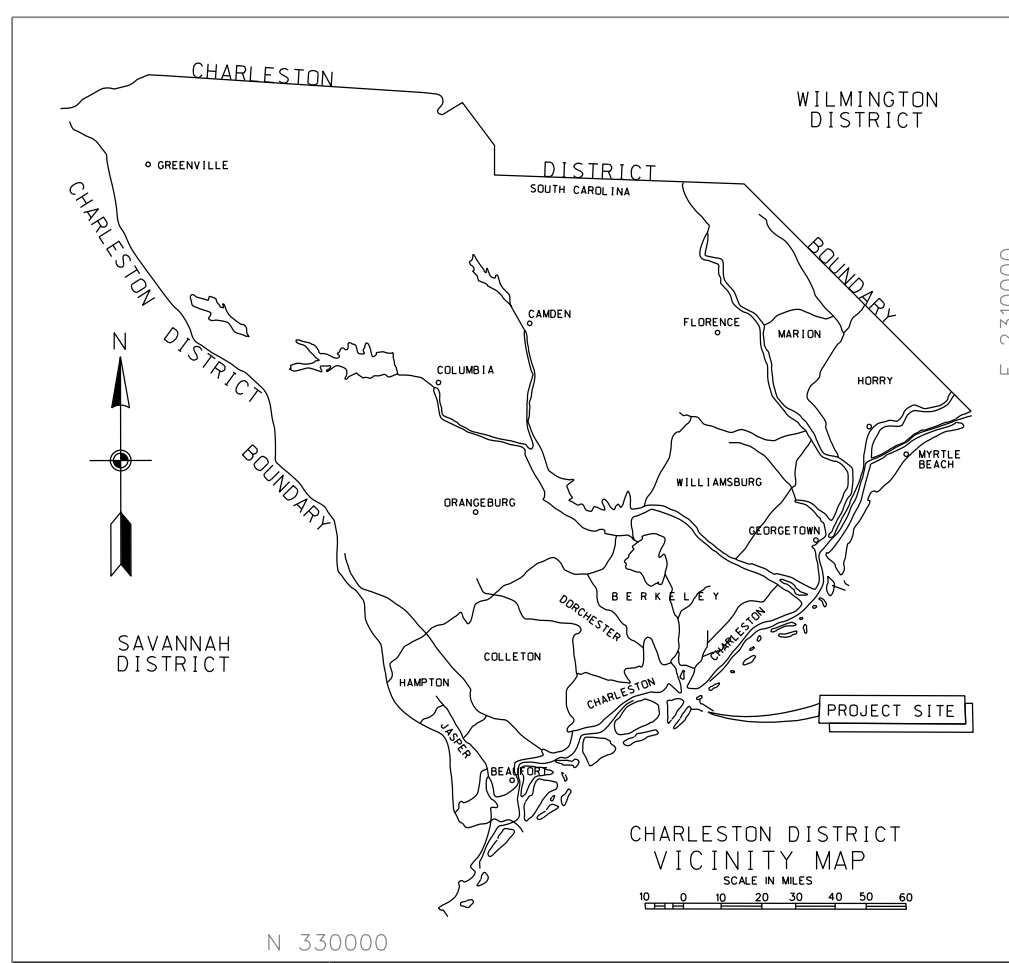

NOTES:  
1. ALL HORIZONTAL COORDINATES ARE BASED ON THE SOUTH CAROLINA STATE PLANE COORDINATE SYSTEM, NAD83 (NGRS2017).

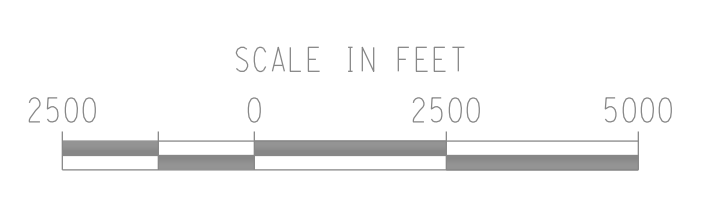

MARK	DESCRIPTION	DATE	APPROV.

Designed by: JJK	Date: 04 MAY 2023	Permit No.:
Checked by: JJK	Scale: N/C	
Reviewed by: JRJ		

U.S. ARMY ENGINEER DISTRICT  
CHARLESTON DISTRICT  
CHARLESTON, SC

SAC #:

UNITED STATES COAST GUARD  
MAINTENANCE DREDGING  
**PERMIT PLANS**  
PLACEMENT AREA OVERVIEW

CHARLESTON & BERKELEY COUNTIES, SOUTH CAROLINA

SHEET  
REFERENCE  
NUMBER  
**C-08**  
SHEET 1 OF 1