

JOINT
PUBLIC NOTICE

CHARLESTON DISTRICT, CORPS OF ENGINEERS
69A Hagood Avenue
Charleston, South Carolina 29403-5107
and the
S.C. DEPARTMENT OF HEALTH AND ENVIRONMENTAL CONTROL
OFFICE OF OCEAN AND COASTAL RESOURCE MANAGEMENT
1362 McMillan Avenue, Suite 400
Charleston, South Carolina 29405

REGULATORY DIVISION

Refer to: P/N #SAC-2013-00574-2IG

18 JUNE 2013

Pursuant to Section 10 of the Rivers and Harbors Act of 1899 (33 U.S.C. 403), Sections 401 and 404 of the Clean Water Act (33 U.S.C. 1344), and the South Carolina Coastal Zone Management Act (48-39-10 et seq.) an application has been submitted to the Department of the Army and the S.C. Department of Health and Environmental Control by

THE U. S. FISH AND WILDLIFE SERVICE (USFWS)
C/O MS. SARAH DAWSEY, REFUGE MANAGER
5801 HIGHWAY 17 NORTH
AWENDAW, SOUTH CAROLINA 29429

for a permit to perform excavation, place fill material and install water control structures in waters of the existing Jack's Creek impoundment adjacent to the

ATLANTIC OCEAN

at locations, within the existing Jack's Creek impoundment on Bull's Island, in the USFWS Cape Romain National Wildlife Refuge, near Awendaw, Charleston County, South Carolina.
(Latitude 32.91751° - Longitude -79.58477°)

In order to give all interested parties an opportunity to express their views

NOTICE

is hereby given that written statements regarding the proposed work will be received by the **Corps** until

15 Days from the Date of this Notice,

and **SCDHEC** will receive written statements regarding the proposed work until

30 Days from the Date of this Notice

from those interested in the activity and whose interests may be affected by the proposed work.

The proposed work consists of performing excavation by long reach excavator to construct borrow ditches in approximately 8.1 acres of wetlands in the existing impoundment and placing the excavated fill material in approximately 8.1 acres of wetlands in the existing impoundment to construct a 5,348 long earthen cross field dike and construct a 955' earthen cross field dike. Each cross field dike will have a bottom width of approximately 56.66' and a top width of 20'. Approximately 16.3 acres of brackish water wetlands within the existing impoundment will be

impacted by the proposed work. In addition, the applicant will install two rice trunks and one double flashboard riser in the constructed cross dikes for water control capability. Due to the nature of the proposed work and beneficial impacts including beneficial impacts to water quality, the applicant has not proposed compensatory mitigation for the proposed work. The purpose of the proposed work is for protection of the freshwater interior fields in the event of salt water encroachment from ocean side dike failure; for water quality improvements including the reduction of fecal coliform levels in surrounding estuarine waters during draw downs by allowing the refuge more control of water levels for timed water releases; and to allow more efficient and more options for management capabilities.

NOTE: Plans depicting the work described in this notice are available and will be provided, upon receipt of a written request, to anyone that is interested in obtaining a copy of the plans for the specific project. The request must identify the project of interest by public notice number and a self-addressed stamped envelope must also be provided for mailing the drawings to you. Your request for drawings should be addressed to the

**U.S. Army Corps of Engineers
ATTN: REGULATORY DIVISION
69A Hagood Avenue
Charleston, South Carolina 29403-5107**

The District Engineer has concluded that the discharges associated with this project, both direct and indirect, should be reviewed by the South Carolina Department of Health and Environmental Control in accordance with provisions of Section 401 of the Clean Water Act. As such, this notice constitutes a request, on behalf of the applicant, for certification that this project will comply with applicable effluent limitations and water quality standards. The work shown on this application must also be certified as consistent with applicable provisions the Coastal Zone Management Program (15 CFR 930). The District Engineer will not process this application to a conclusion until such certifications are received. The applicant is hereby advised that supplemental information may be required by the State to facilitate the review.

This notice initiates the Essential Fish Habitat (EFH) consultation requirements of the Magnuson-Stevens Fishery Conservation and Management Act. Implementation of the proposed project would impact (16.3) acres of brackish substrates adjacent to estuarine substrates and emergent wetlands utilized by various life stages of species comprising the red drum, shrimp, and snapper-grouper management complexes. Our initial determination is that the proposed action would not have a substantial individual or cumulative adverse impact on EFH or fisheries managed by the South Atlantic Fishery Management Council and the National Marine Fisheries Service (NMFS). Our final determination relative to project impacts and the need for mitigation measures is subject to review by and coordination with the NMFS.

The District Engineer has consulted the most recently available information and has determined that the project will have no effect on any federally endangered, threatened, or proposed species and will not result in the destruction or adverse modification of designated or proposed critical habitat. This public notice serves as a request to the U.S. Fish and Wildlife Service and the National Marine Fisheries Service for any additional information they may have on whether any listed or proposed endangered or threatened species or designated or proposed critical habitat may be present in the area which would be affected by the activity, pursuant to Section 7(c) of the Endangered Species Act of 1973 (as amended).

Pursuant to Section 106 of the National Historic Preservation Act (NHPA), this public notice also constitutes a request to Indian Tribes to notify the District Engineer of any historic

properties of religious and cultural significance to them that may be affected by the proposed undertaking.

In accordance with the NHPA, the District Engineer has also consulted the latest published version of the National Register of Historic Places for the presence or absence of registered properties, or properties listed as being eligible for inclusion therein, and this worksite is not included as a registered property or property listed as being eligible for inclusion in the Register. To insure that other cultural resources that the District Engineer is not aware of are not overlooked, this public notice also serves as a request to the State Historic Preservation Office to provide any information it may have with regard to historic and cultural resources.

Any person may request, in writing, within the comment period specified in this notice, that a public hearing be held to consider this application. Requests for a public hearing shall state, with particularity, the reasons for holding a public hearing.

The decision whether to issue a permit will be based on an evaluation of the probable impact including cumulative impacts of the activity on the public interest and will include application of the guidelines promulgated by the Administrator, Environmental Protection Agency (EPA), under authority of Section 404(b) of the Clean Water Act and, as appropriate, the criteria established under authority of Section 102 of the Marine Protection, Research and Sanctuaries Act of 1972, as amended. That decision will reflect the national concern for both protection and utilization of important resources. The benefit which reasonably may be expected to accrue from the project must be balanced against its reasonably foreseeable detriments. All factors which may be relevant to the project will be considered including the cumulative effects thereof; among those are conservation, economics, aesthetics, general environmental concerns, wetlands, historic properties, fish and wildlife values, flood hazards, flood plain values, land use, navigation, shoreline erosion and accretion, recreation, water supply and conservation, water quality, energy needs, safety, food and fiber production and, in general, the needs and welfare of the people. A permit will be granted unless the District Engineer determines that it would be contrary to the public interest. In cases of conflicting property rights, the Corps of Engineers cannot undertake to adjudicate rival claims.

The Corps of Engineers is soliciting comments from the public; Federal, state, and local agencies and officials; Indian Tribes; and other interested parties in order to consider and evaluate the impacts of this activity. Any comments received will be considered by the Corps of Engineers to determine whether to issue, modify, condition or deny a permit for this project. To make this decision, comments are used to assess impacts on endangered species, historic properties, water quality, general environmental effects, and the other public interest factors listed above. Comments are used in the preparation of an Environmental Assessment and/or an Environmental Impact Statement pursuant to the National Environmental Policy Act. Comments are also used to determine the need for a public hearing and to determine the overall public interest of the activity.

If there are any questions concerning this public notice, please contact **Mary Hope Green** at 843-329-8044 or toll free at 1-866-329-8187.

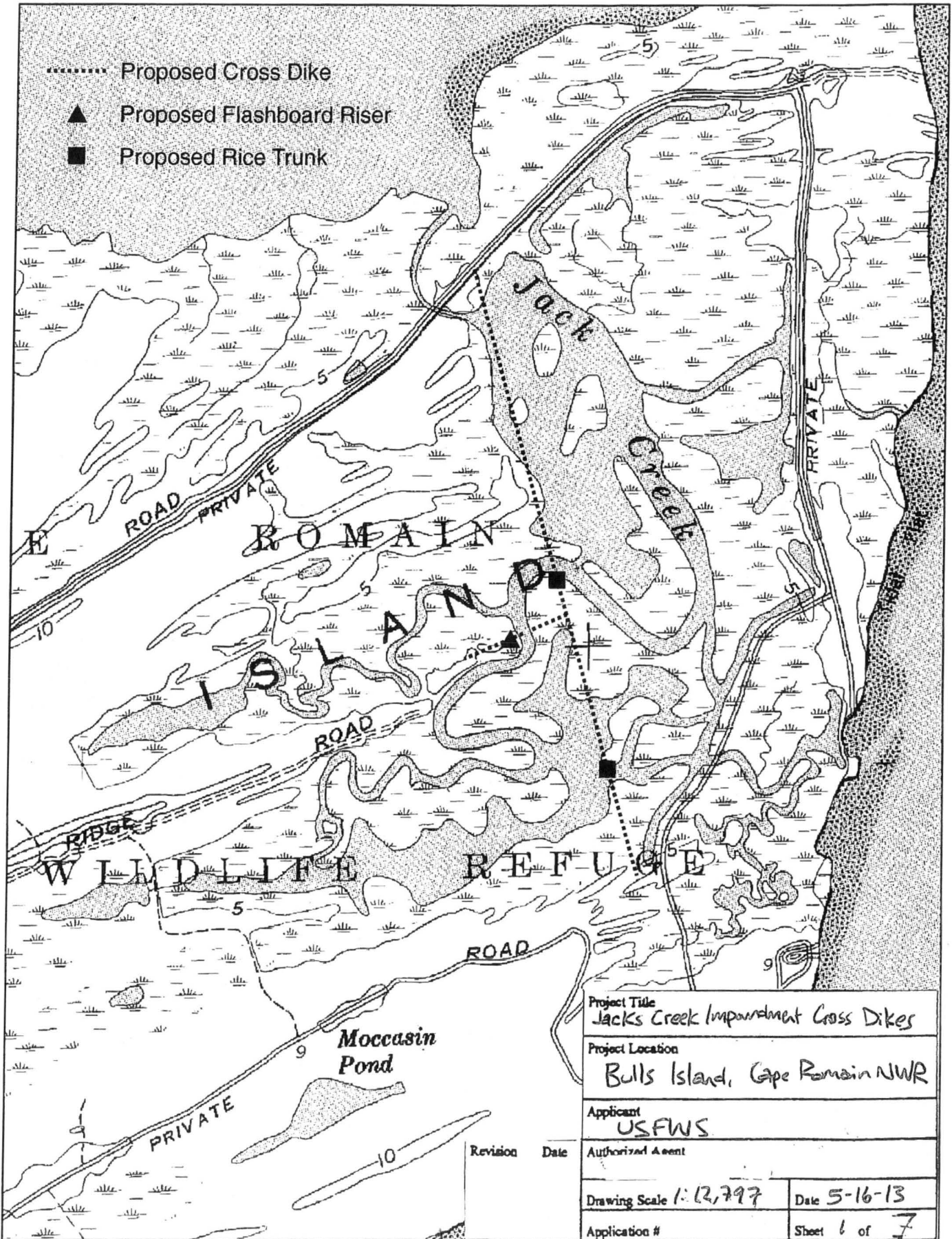

Project Title Jacks Creek Impairment Cross Dikes	
Project Location Bulls Island, Cape Romain NWR	
Applicant USFWS	
Authorized Agent	
Revision	Date
Drawing Scale 1:12,797	
Date 5-16-13	
Application #	Sheet 1 of 7

#SAC-2013-00574-2IG

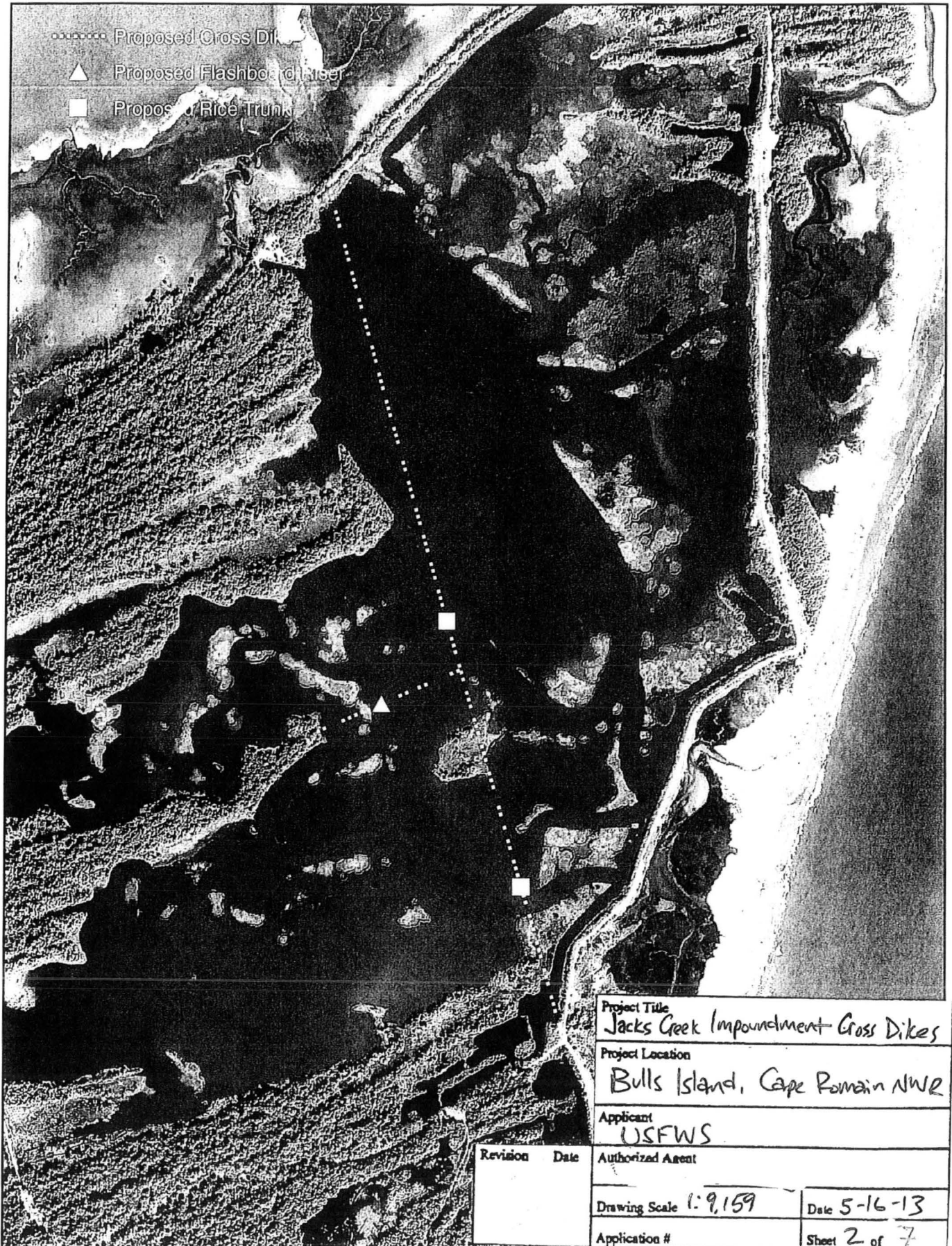

Project Title
 Jacks Creek Impoundment Cross Dikes

Project Location
 Bulls Island, Cape Romain NWR

Applicant
 USFWS

Revision	Date	Authorized Agent
Drawing Scale 1:9,159		Date 5-16-13
Application #		Sheet 2 of 7

#SAC-2013-00574-ZIG



- Proposed Cross Dike
- ▲ Proposed Flashboard Riser
- Proposed Rice Trunk

Project Title		Jacks Creek Impoundment Cross Dikes	
Project Location		Bulls Island, Cape Roman NWR	
Applicant		USFWS	
Authorized Agent			
Revision	Date	Drawing Scale	Date
		1:9,159	5-16-13
Application #		Sheet 3 of 7	

#SAC - 2013-574-ZIG

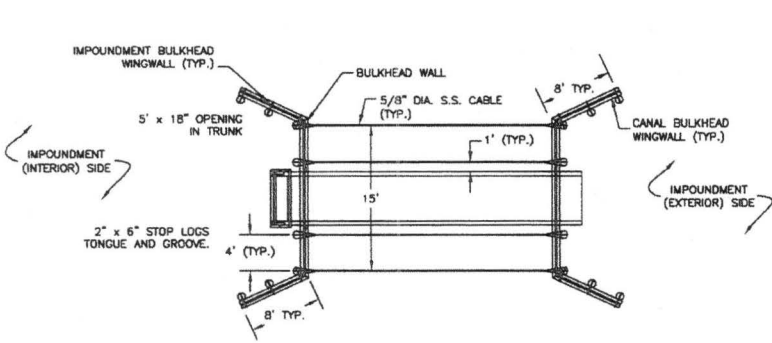

PLAN VIEW

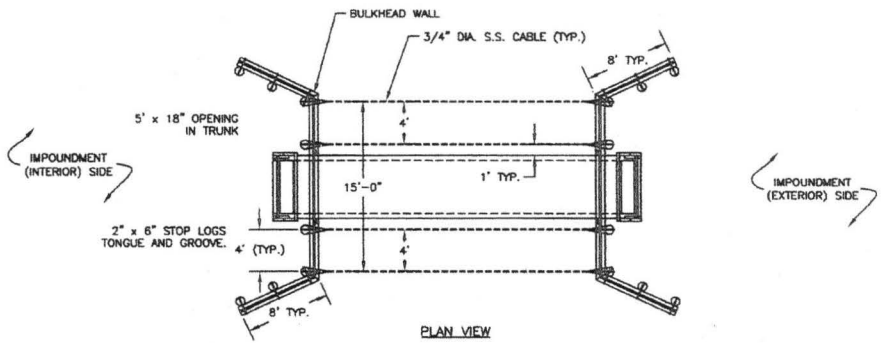

PLAN VIEW

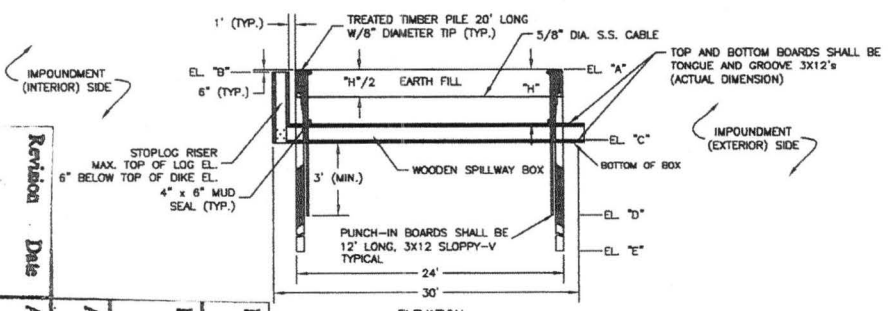

ELEVATION

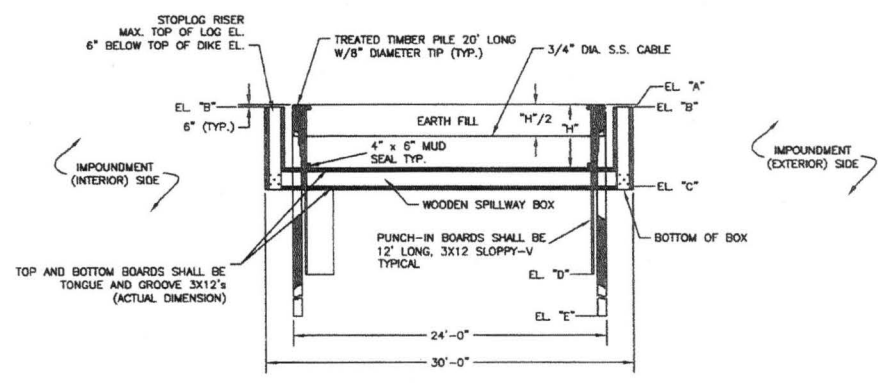

ELEVATION

DOUBLE SPILLWAY BOX DETAILS

NOT TO SCALE

SPILLWAY BOX DETAILS

NOT TO SCALE

SPILLWAY BOX TABLE					
TRUNK SIZE INSIDE DIMENSION	EL. "A"	EL. "B"	EL. "C"	EL. "D"	EL. "E"
5' x 18"	4.0	3.5	-3.0	-8.0	-16.0
5' x 18"	4.0	3.5	-3.0	-8.0	-16.0
5' x 18"	4.0	3.5	-3.5	-8.0	-16.0
5' x 18"	4.0	3.5	-2.5	-8.0	-16.0
5' x 18"	4.0	3.5	-2.5	-8.0	-16.0

DOUBLE SPILLWAY BOX TABLE						
STRUCTURE	TRUNK SIZE INSIDE DIMENSION	EL. "A"	EL. "B"	EL. "C"	EL. "D"	EL. "E"
PROPOSED DOUBLE SPILLWAY BOX #1	5' x 18"	3.5	3.0	-3.0	-8.5	-16.0

NOTES:

- THE CONTRACTOR IS RESPONSIBLE FOR DEWATERING AND CONSTRUCTING COFFER DAMS AS NECESSARY TO ALLOW FOR THE INSTALLATION OF THE STRUCTURE. AFTER COMPLETION OF THE STRUCTURE INSTALLATION, THE CONTRACTOR SHALL REMOVE ANY COFFER DAMS AND RESHAPE THE GROUND AND CANAL TO THE PRECONSTRUCTION ELEVATIONS AND SHAPE.
- THE CONTRACTOR IS RESPONSIBLE FOR THE REMOVAL OF ALL MATERIAL WHICH MAY BE PRESENT THAT MAY INHIBIT THE DRIVING OF THE TIMBER PILES AND VERTICAL 3 x 12 MEMBERS.
- THE CONTRACTOR SHALL FIELD VERIFY ALL MEASUREMENTS BEFORE ORDERING MATERIALS.
- THE CONTRACTOR IS RESPONSIBLE FOR THE REMOVAL OF THE EXISTING ALUMINUM RISER.

NOTICE:
 THIS DOCUMENT IS RELEASED FOR THE PURPOSE OF INTERIM REVIEW UNDER THE AUTHORITY OF JAMES W. WEBSTER, P.E. 19618, ON NOVEMBER 2, 2011. IT IS NOT TO BE USED FOR CONSTRUCTION, BIDDING, OR PERMIT PURPOSES.

DUCKS UNLIMITED INC. 1000 Highway 100, Suite 100 Columbia, SC 29927 C.C. & B. COOPER ENGINEERS, S.E./P.E.	PROJECT NO.	DESIGNED BY: JTW
	SPILLWAY BOX DETAILS	DRAWN BY: BCP
DATE: 11/11	CHECKED BY:	APPROVED BY:

#SAC-2013-574-2IG

Revision	Date	Authorizing Agent
Drawing Scale	Date	Sheet
	5-16-13	4 of 7

Applicant: USFWS
 Project Location: Bulls Island, Cape Romain NWR
 Project Title: Jacks Creek Impoundment Cross Dikes

FOR CONTROL STRUCTURES SHALL BE BY A COMPANY SPECIALIZING IN SUCH STRUCTURES WITH NOT LESS THAN FIVE YEARS OF DOCUMENTED EXPERIENCE IN THE CONSTRUCTION OF WOODEN WATER CONTROL STRUCTURES. APPROVAL OF SUCH CONTRACTOR BY THE ENGINEER SHALL BE MANDATORY PRIOR TO CONSTRUCTION.

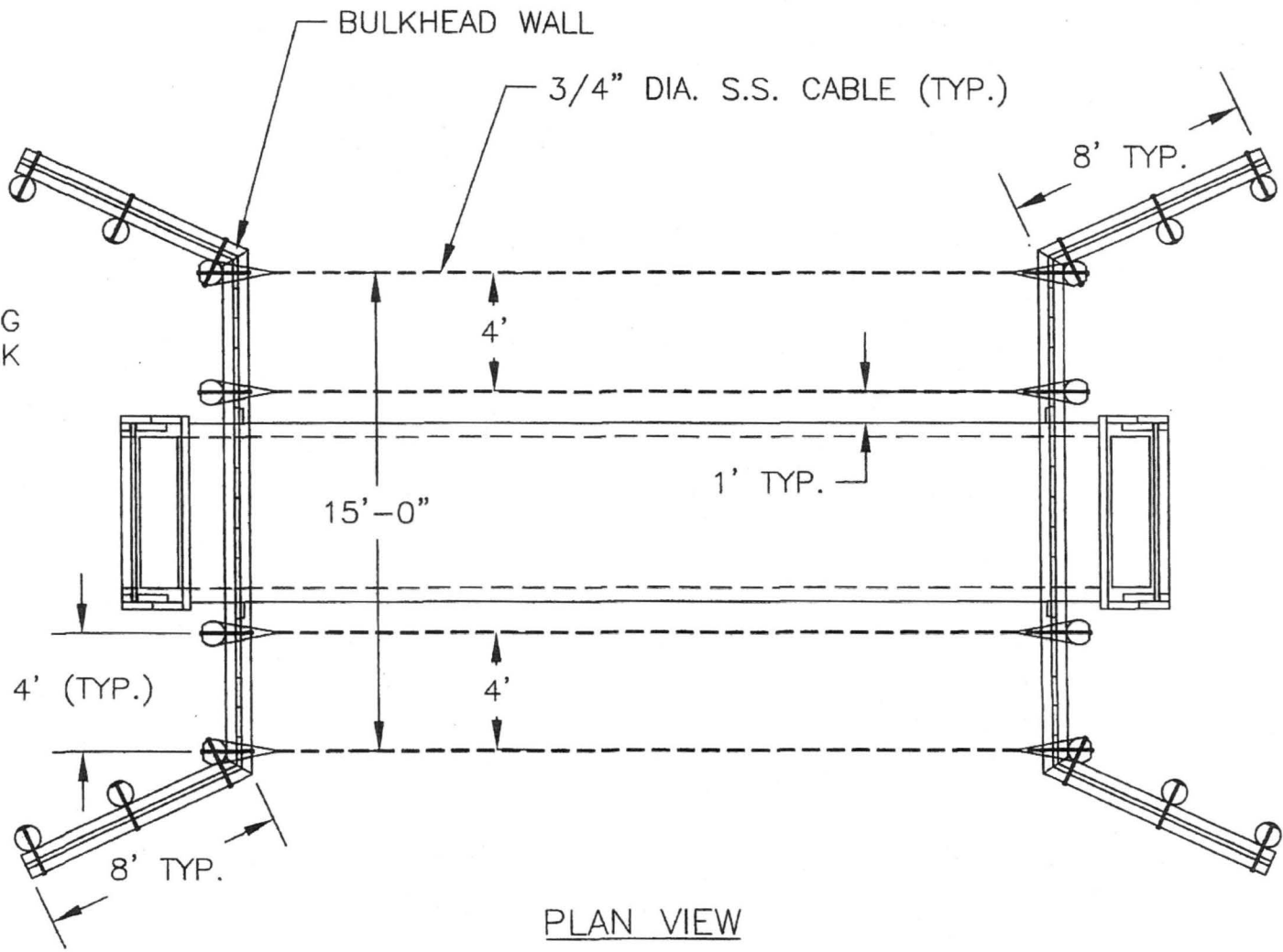

5' x 18" OPENING IN TRUNK

BULKHEAD WALL

3/4" DIA. S.S. CABLE (TYP.)

8' TYP.

4'

1' TYP.

15'-0"

4' (TYP.)

4'

8' TYP.

PLAN VIEW

ADJUTMENT (R) SIDE

2" x 6" STOP LOGS TONGUE AND GROOVE.

#SAC-2013-00574-2IF	Revision	
	Date	
Application #	Authorized Agent	
Drawing Scale	Applicant	
Date 5-16-13	USFWS	
Sheet 5 of 7	Project Location	Bulls Island, Cape Romain NWR
	Project Title	Jacks Creek Impoundment Cross Dikes

OR LOG DISCED

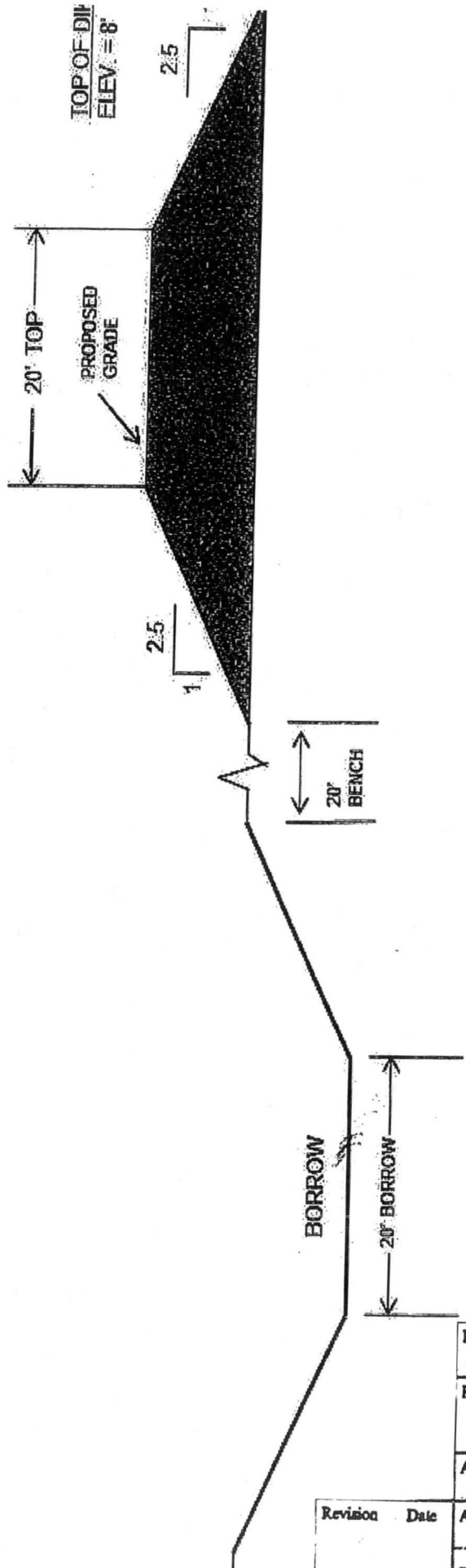

Project Title	Jacks Creek Impoundment Cross Dikes	
Project Location	Bulls Island, Cape Roman NWR	
Applicant	USFWS	
Revision	Date	Authorized Agent
Drawing Scale	Date 5-16-13	
Application #	Sheet 6 of 7	

#SAC-2013-00574-ZIG

- Existing Roads and Dikes
- ▲ Proposed Flashboard Riser
- Proposed Rice Trunk
- ▨ Proposed Cross Dike

Proposed borrow ditches to 20' off to the west of the 5,348' dike and 20' off the north of the 955' dike.

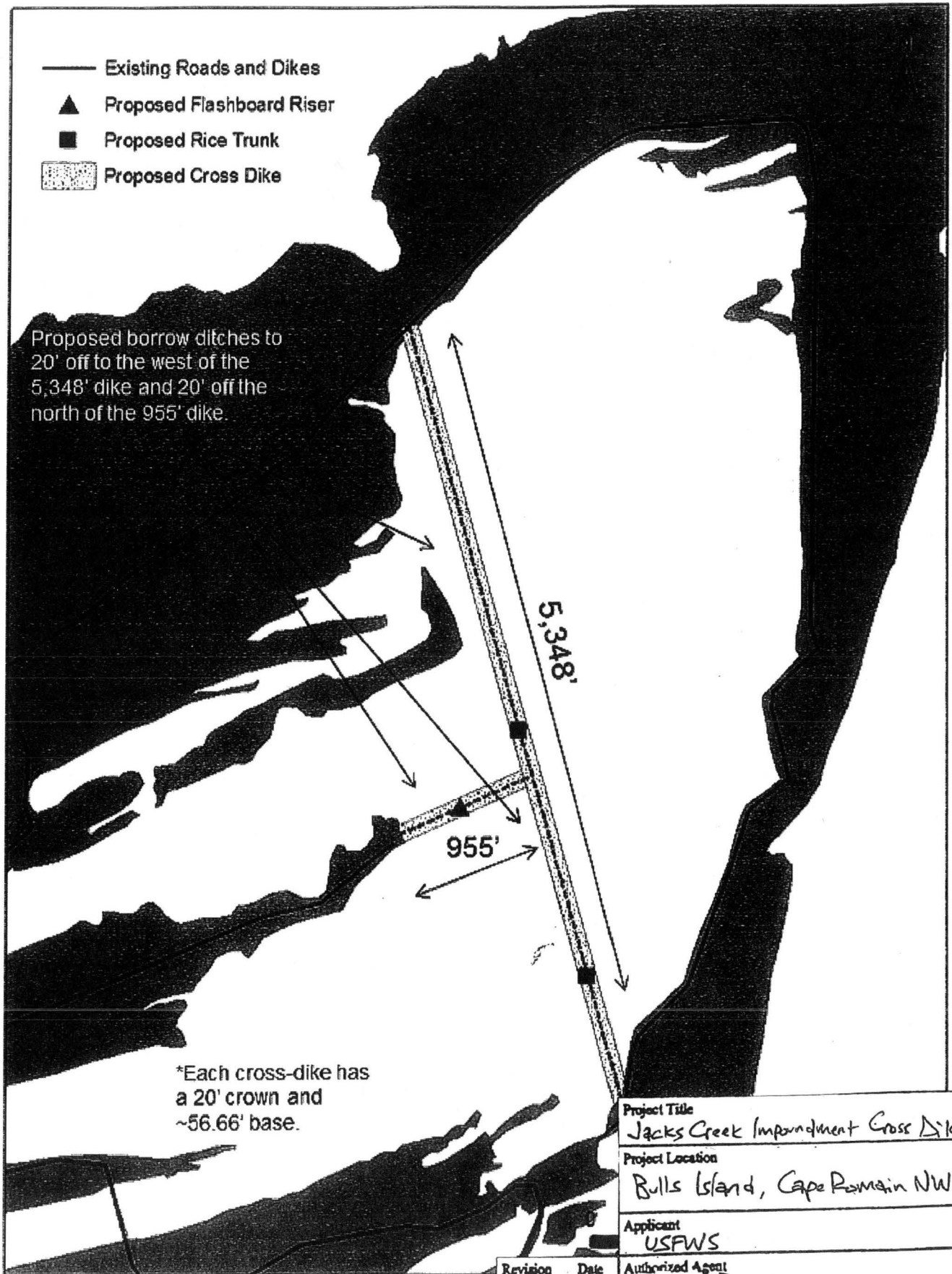

*Each cross-dike has a 20' crown and ~56.66' base.

Project Title	
Jacks Creek Impoundment Cross Dikes	
Project Location	
Bulls Island, Cape Roman NWR	
Applicant	
USFWS	
Authorized Agent	
Drawing Scale	Date
1:9,913	5-16-13
Application #	Sheet
#SAC-2013-574-2IG	7 of 7

Revision	Date

32. Description of the Overall Project and of Each Activity in or Affecting U.S. Waters or State Critical Areas

The project entails the construction of an earthen cross-dike approximately 5,348 feet long running in a straight south-southeast trajectory from 32°55'31.57" N 79°35'09.79" W to 32°54'42.37" N 79°34'52.47", which would bisect the Jacks Creek impoundment on Bulls Island at Cape Romain National Wildlife Refuge. The project would also include the construction of an earthen cross-dike approximately 955' connecting an upland peninsula at Jacks Creek at 32°54'59.71" N 79°35'09.87 W to the larger proposed 5,348' long cross-dike at 32°55'03.74" N 79°34'59.67" W (see attached maps).

The cross-dikes would have 20' crowns with 20' 2.5:1 side slopes and 56.66' bases. Together, the cross-dikes would account for a footprint of approximately 355,867 square feet. Their construction would necessitate the excavation borrow ditches impacting 355,867 square feet of waters immediately adjacent to the proposed cross-dikes and would require approximately 71,583 yd³ of sediment to construct, with 29,181 yd³ affecting waters there from filling (assuming an average impoundment depth of 2.5'). Additionally, the project would entail the installation of a double-flashboard riser on the 955' dike at 32°55'06.74" N 79°35'00.77 W and two rice trunks on the 5,348' dike at approximately 32°54'52.38" N 79°34'55.49" W and 32°55'06.68" N 79°33'01.64" W.

33. Overall Project Purpose and the Basic Purpose of Each Activity in or Affecting U.S. Waters Construction of a Cross-Dike in Jacks Creek Impoundment

Jacks Creek impoundment is managed for a variety of migratory birds, including waterfowl, shorebirds, and wading birds. At approximately 485 acres, it is the largest impoundment on Bulls Island and supports the majority of waterfowl use there. It is impounded on its Atlantic side by a one-mile stretch of dike which is separated from the ocean by roughly 200 feet of beach at the narrowest point; this section of beach erodes at a rate of 25-30 feet per year, which will lead to a breach within the next 6-8 years, barring no tropical storm activity (which would expedite this). As climate continues to change, sea levels are expected to rise and storms are expected to become more severe. This poses an ongoing threat to the aforementioned dike, which has been systematically breached in the past due to its parallel juxtaposition with the ocean. Breaching of this dike would convert the entire 485-acre impoundment to a tidally-influenced saltwater system that is unproductive for growing waterfowl foods or for wildlife dependent on its brackish waters.

Taking no action on the ocean-facing dike will ultimately require additional patchwork to repair the impoundment from saltwater inundation. However, the creation of a cross-dike running perpendicular to the ocean-facing dike (see attached maps) would ensure that 254.5 acres of Jacks Creek west of the proposed dike would remain manageable to the benefit of migratory birds as well as wildlife dependent on fresh to brackish waters, whereas the 230.3 acres of Jacks Creek east of the proposed dike would revert back to natural tidal salt marsh. The transformation

of 230 acres of wetlands from brackish to salt marsh would benefit wildlife species dependent on salt water marshes such as rails, marsh sparrows, and diamondback terrapins.

Salinity levels in the remaining 255 acres of brackish water (which would be subdivided into two impoundments, 142 and 113 acres in size) would more easily react to rainfall events as opposed to the current 485-acre impoundment, which, due to its size, does not react quickly or in great magnitude to normal rainfall events. In addition, this project would aid the management of fecal coliforms that build up in impoundments by allowing the refuge to execute timed releases of water. This would benefit surrounding estuarine and marine waters by reducing fecal coliform concentration when drawn downs occur and impounded water is released.

The addition of the 955' cross-dike connecting an upland peninsula to the 5,348' cross-dike as well as its proposed double-flashboard riser would create two brackish impoundments that could be managed for different migratory bird species simultaneously, if desired. For example, the northern 113-acre impoundment could be managed for growing waterfowl food plants while at the same time the refuge could manage the southern 142-acre impoundment for shorebirds or wading birds. Furthermore, the two impoundments created by the cross-dikes would serve as a buffer for interior freshwater impoundments on the island, such as Pools 1, 2, and 3 and Big Pond. These freshwater bodies are impounded by dikes that are 2' lower in elevation than the dikes that surround the outside of Jacks Creek. Therefore, if Jacks Creek were to be breached in its current state, a surge of salt water would inundate interior impoundments. This would create dire consequences for the birds, reptiles, amphibians and mammals on Bulls Island who rely on fresh waters.

The proposed rice trunks to be installed on the 5,348' cross-dike would be strategically located where the historic Jacks Creek used to flow (see map). When the ocean-facing dike does breach and the area east of the cross-dike reverts back to tidal salt marsh, the creek is likely to assume the path of least resistance, i.e., its historic bed. Thus, the location of the rice trunks at the aforementioned coordinates would allow the refuge to easily and consistently drain/draw water to/from this tidal salt water creek.

The borrow ditches to be excavated for construction of each dike would later be used as conveyance channels which would allow for the flooding and draining of the two managed impoundments.

39. Describe measures taken to avoid and minimize impacts to Waters of the United States:

Where possible, the refuge would utilize preexisting topographical features to reduce the impacts to waters in Jacks Creek impoundment. The 5,348' cross-dike would tie into high marsh hammocks such as the 2.7-acre hammock located at 32°54'58.79" N 79°34'59.22" W. The 955' cross-dike would be situated off of an upland peninsula so as to reduce the need to construct a longer cross-dike elsewhere. In addition, the refuge would install turbidity barriers at all points

of discharge to control floating silt. This project would be completed entirely inside a managed impoundment that is isolated from surrounding U.S. waters by a series of dikes.

40. Provide a brief description of the proposed mitigation plan to compensate for impacts to aquatic resources or provide justification as to why mitigation should not be required.

Mitigation should not be required for this project because the benefits to wildlife and environmental health outweigh the impacts to the waters of Jacks Creek. Construction of the described cross-dikes would benefit wildlife species dependent on brackish/fresh waters by ensuring the existence of two brackish water impoundments which would total 255 acres. The reduced impoundment sizes would allow salinity levels to respond quicker to rainfall events; this in turn would lead to the continued promotion of waterfowl food plants. The two brackish water impoundments would serve as a buffer against salt water surges, which in turn would protect freshwater interior impoundments on Bulls Island.

In addition, the reversion of 230 acres of brackish marsh to salt marsh would benefit salt marsh dependent species. The project would also encourage greater aquatic/environmental health by allowing the refuge to better manage water releases and fecal coliform concentrations in the impoundment. Lastly, the reversion of 230 acres of habitat to its natural state would be a service to the public on the mainland as it would serve as a better buffer against storm events.

42. List all Corps Permit Authorizations and other Federal, State, or Local Certifications, Approvals, Denials received for work described in this application.

The most recent permitted work at the proposed projected site was in November 2008, when the rice trunk situated at 32°55'28.34" N 79°35'14.33" W blew out, requiring emergency repair work.